

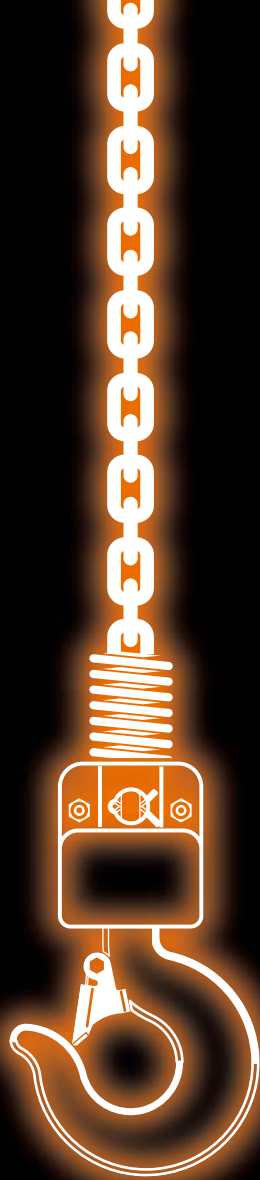

Chain Hoist

HITACHI
Inspire the Next



Hitachi ChainHoist Catalog

Hitachi Electric Chain HOIST

L series

S series

F series

Hitachi Electric Chain Hoist

Widely used to improve the efficiency of material handling (and transportation).

Hitachi chain hoist can be used for a wide range of purposes from primary to tertiary industries such as general machine, vehicle and car manufacturing factories as well as warehouses and retail stores.



Contents

● Introduction ————— 1-2

Outline

● List of Model Series ————— 3

● Standard Specifications ————— 4

● Model Explanation ————— 4

● Series Selection ————— 4

● Operating Conditions and Model Selection Method — 5

● Standard Specifications Quick Reference — 6

● Features

Standard Model ————— 7-8

CE Marking Model ————— 9-10

L series

● Suspension type ————— 11

● 2-point Pushbutton Switch type ————— 12

● 3-point Pushbutton Switch type ————— 12

S series

■ Suspension type ————— 13-14

● With motorized trolley - ET ————— 15

● With motorized trolley - ST ————— 16

● With chain driven trolley - BC ————— 17

● With manual driven trolley - BP ————— 18

F series

● Suspension type ————— 19-20

● With motorized trolley - ET ————— 21

● With motorized trolley - ST ————— 22

● With chain driven trolley - BC ————— 23

● With manual driven trolley - BP ————— 24

Others

● Crane wiring unit ————— 25

● Dedicated electric chain hoist ————— 26-28

● Technical materials ————— 29

Outline

L series

S series

F series

Others

The electric chain hoist is only meant for transporting cargo. It is not to be used for hoisting and transporting people.

You can make an exacting model selection based on such operating conditions as capacity and speed.

L series Higher durability, speed and safety with compact body developed for light load daily use.

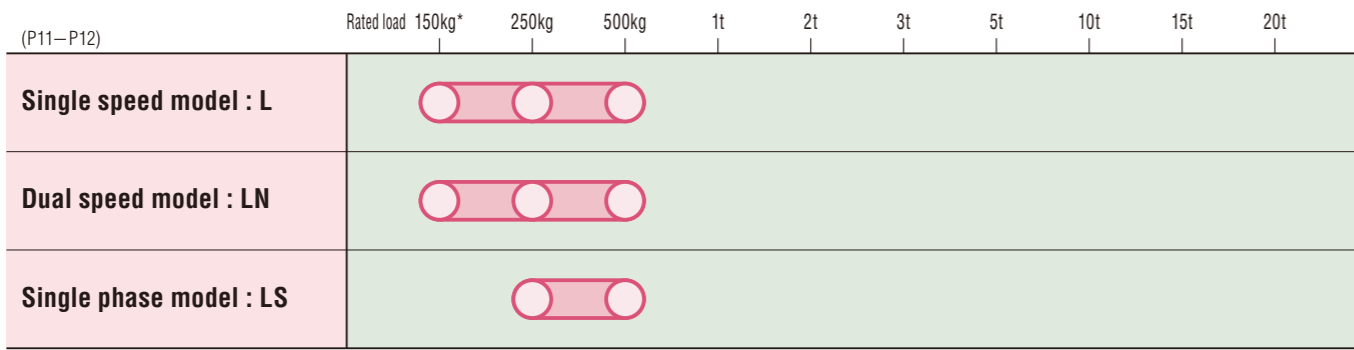

*Without overload limiter device

S series Suitable for general work. Economical standard speed model.

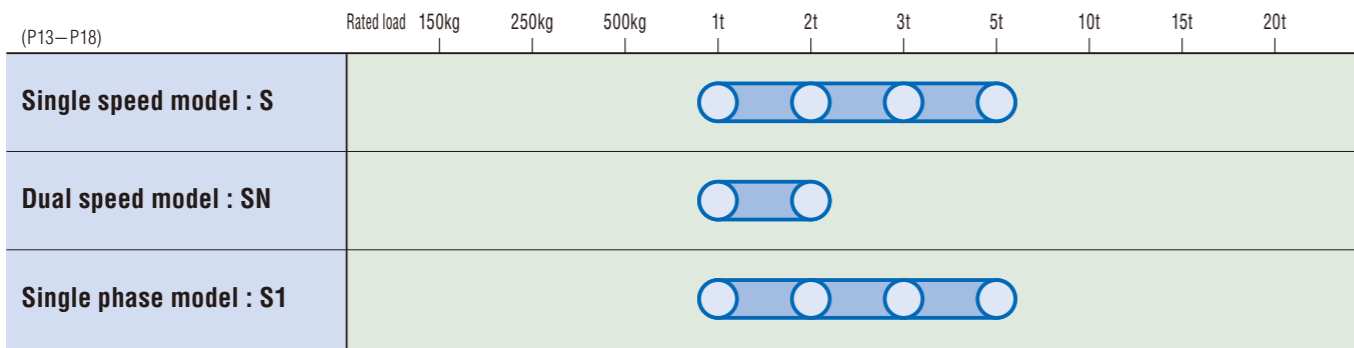

F series High-speed model that is sturdy and suitable for high-speed work.

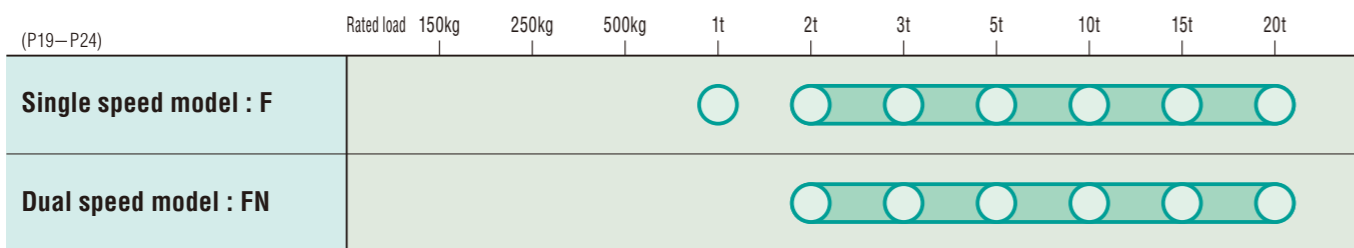

Trolley series

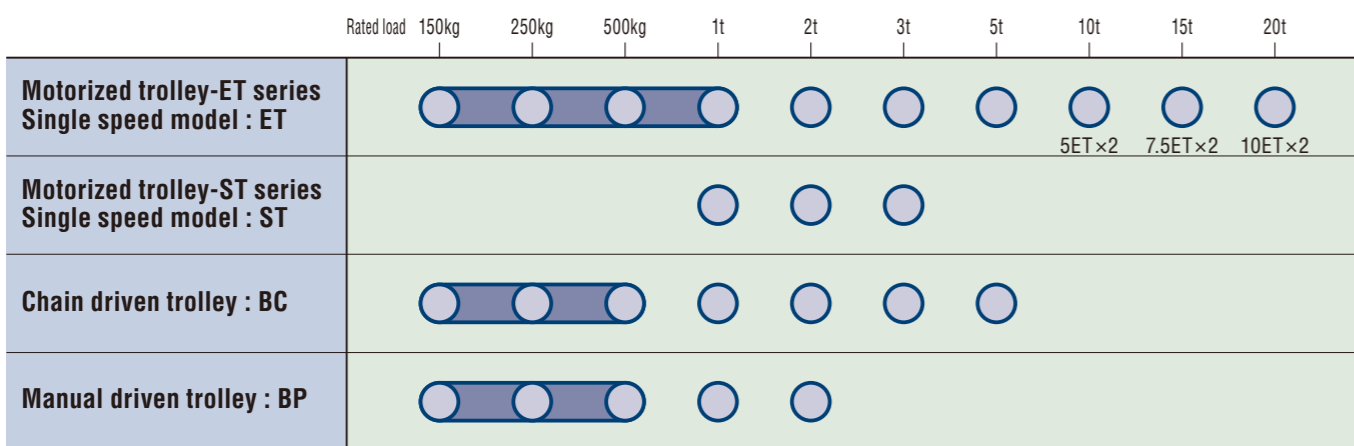

Dedicated electric chain hoist contents

- Twin hook type electric chain hoist — 26
- Optional power source electric chain hoist and trolley — 27
- Optional control voltage model — 27
- Electric chain hoist with the Hi-plated chain — 27
- Electric chain hoist with overload prevention unit (with OL) — 27
- With geared limit switch (UDS) — 27
- Other products with changed specifications
Lift change (extension), etc. — 28-29

Standard Specifications

Specifications		Standard model	CE Making model
Power Source*	50Hz	3 phase : 220/380-415V 3 phase : 346-380V 1 phase : 200-220V	1 phase : 220-240V
	60Hz	3 phase : 220V, 220-230/440-460V 1 phase : 110V, 220V	—
Operation Method	Operating pushbutton		
Control Voltage	24V		
Power Method	Suspension type with manual driven trolley or chain driven trolley : with 5m cable With motorized trolley : cable and catch are not included with standard shipment		
Pushbutton Switch	2(3)	single speed	↑ ↓ (STOP) ↑ ↓
		dual speed	↑ ↓ (STOP) ↑ ↓
	4(5)	single speed	↑ ↓ ← → (STOP) ↑ ↓ ← →
		dual speed	↑ ↓ ← → (STOP) ↑ ↓ ← →
6(7)	single speed	↑ ↓ ← → ↻ ↻ (STOP) ↑ ↓ ← → ↻ ↻	
	dual speed	↑ ↓ ← → ↻ ↻ (STOP) ↑ ↓ ← → ↻ ↻	
Color(Munsell)	Orange(2.5YR 6/12)		
Electrical Protection	IP54(Trolley : IP44) (Equivalent when stuffing drain hole)		
Insulation Class of Motor	E		
Rating**	30%ED, 180starts/h(F series)***		
Classification	ISO M4, FEM 1Am		
Standards	—	Machinery : 2006/42/EC	EMC : 2004/108/EC

* For power sources other than those listed, see the dedicated electric chain hoists (page25).
 ** This shows the value at a load of 63% of the rated load.
 ** Make sure the average value per hour is not exceeded even during concentrated use in a short time.
 ** Dual speed models have an added low speed to allow fine movement operation and improve workability by reducing inching. The rating shows the value when the high speed and the low speed, the operation time of which is 1/10 of the high speed, are combined.
 *** Please refer to each specification table for the model except the F series.

Series Selection

When selecting an electric chain hoist, the operating environment, operating time, and operating frequency must be taken into consideration.

Operating time and load ratio

Use within the range of section.

Hitachi chain hoists belong to M4 classification

Load Condition	Load Ratio	Mean operating hour per day (h)*						Total operating time(h)**						
		0.25	0.5	1	2	4	8	200	400	800	1,600	3,200	6,300	
Light	$K \leq 0.5$							—	—	M1	M2	M3	M4	
Medium	$0.5 < K \leq 0.63$							—	M1	M2	M3	M4	M5	
Heavy	$0.63 < K \leq 0.8$				L, S, F series			M1	M2	M3	M4	M5	M6	
Severe	$0.8 < K$							M2	M3	M4	M5	M6	—	

Load condition

Light : This is normally used at a load of 1/2 the rated load, and on rare occasions at the rated load.
 Medium : This is normally used at a load of 1/2 to 2/3 the rated load, and occasionally at the rated load.
 Heavy : This is normally used at loads above 2/3 the rated load, and often at the rated load.
 Severe : This is mostly used at the rated load or close to this load.

* If use is expected to exceed the above range, then an electric chain hoist with a higher capacity must be selected, so please consult with HITACHI.
 ** Above range is made for machine parts such as gears and bearings.

Operating environment

- Use in locations with an ambient temperature of -10°C to 40°C (with no freezing) and humidity of 90% or less (no condensation).

In addition to the general specifications, (1) starting frequency, (2) duty factor, and (3) load ratio must be taken into consideration.

- Calculation method
(If the calculated value exceeds the standard specification, then it is a dedicated specification.)

(1) Max. starting frequency α (Starts/h) = $2 \times n \times N$

● Example calculation
The starting frequency is the cumulative sum of the inching operation count, so this must be calculated by estimating the number of inchings per hoist round trip.

$2 \times 3 \times 25 = 150 \text{ Starts/h}$

Lifting+Lowering (Number of times) ———— No. of transfer per hour (times)
Inching count (times) per lifting or lowering operation.

(3) Load ratio $K = \sqrt[3]{P_1 t_1 + P_2 t_2 + P_3 t_3 + \dots}$

● Example calculation
When a 0.4t load is suspended on a 1-ton rated load electric chain hoist for a one-way trip, with a no-load return trip. (The lifting sling is 0.3t).

$K = \sqrt[3]{(0.3+0.4)^3 \times 0.5 + 0.3^3 \times 0.5} = 0.57$

In this case, the load condition is comparable to "medium" and the average operating time per day is 2 hours or less. If used for a longer time than this, an electric chain hoist with a higher capacity must be selected.

(2) Duty factor β (%) = $\frac{\text{The total motor ON time (minutes) per hour under the most frequent condition.}}{60 \text{ min}} \times 100 = 2 \times \frac{\ell}{V} \times N \times \frac{1}{60 \text{ min}} \times 100$

● Example calculation

$2 \times \frac{3}{10} \times 25 \div 60 \times 100 = 25\%$

Lift(m) ———— No. of transfer per hour(Times)
Lifting+Lowering (Times) ———— 1 hour (60 min)
Hoisting speed (m/min)

n : Inching count (times) per lifting or lowering operation.
 N : Transport count (times) within 1 hour
 ℓ : Lift(m)
 V : Hoisting speed(m/min)
 $t_1, t_2, t_3 \dots$: Ratio of the operating time of each load to the total operating time
 $P_1, P_2, P_3 \dots$: Each load ratio (ratio of the load to each rated load)

Hitachi Electric Chain Hoists are Packed with Advanced Features

STANDARD MODEL L series **L** / S series **S** / F series **F**

HELICAL GEARING **L S F**

used where practical to provide quiet operation.

LONG LIFE BRAKE UNIT **L S F**

Disk type Electro-Magnetic brake system for steady operation and long life.

AUTOMATIC ADJUSTING BRAKE **F**

are equipped with patent-ed Automatic Adjusting Brake for easier maintenance and added safety. U.S. PAT. 3908802 Germany PAT. 2354044



ELECTRO-MAGNETIC CONTACTOR **L S F**

with mechanical-interlocking against line short by mechanical shock.

POWER CHAIN **L S F**

special (patented) alloy steel chain surface hardened for optimum strength and wear resistance. (U.S. PAT. 3830054)

CHAIN CONTAINER **L S F**

as standard part for safer operation.

LOWER HOOK **L S F**

is heat-treated and equipped with safety latch and 360° swivelling.

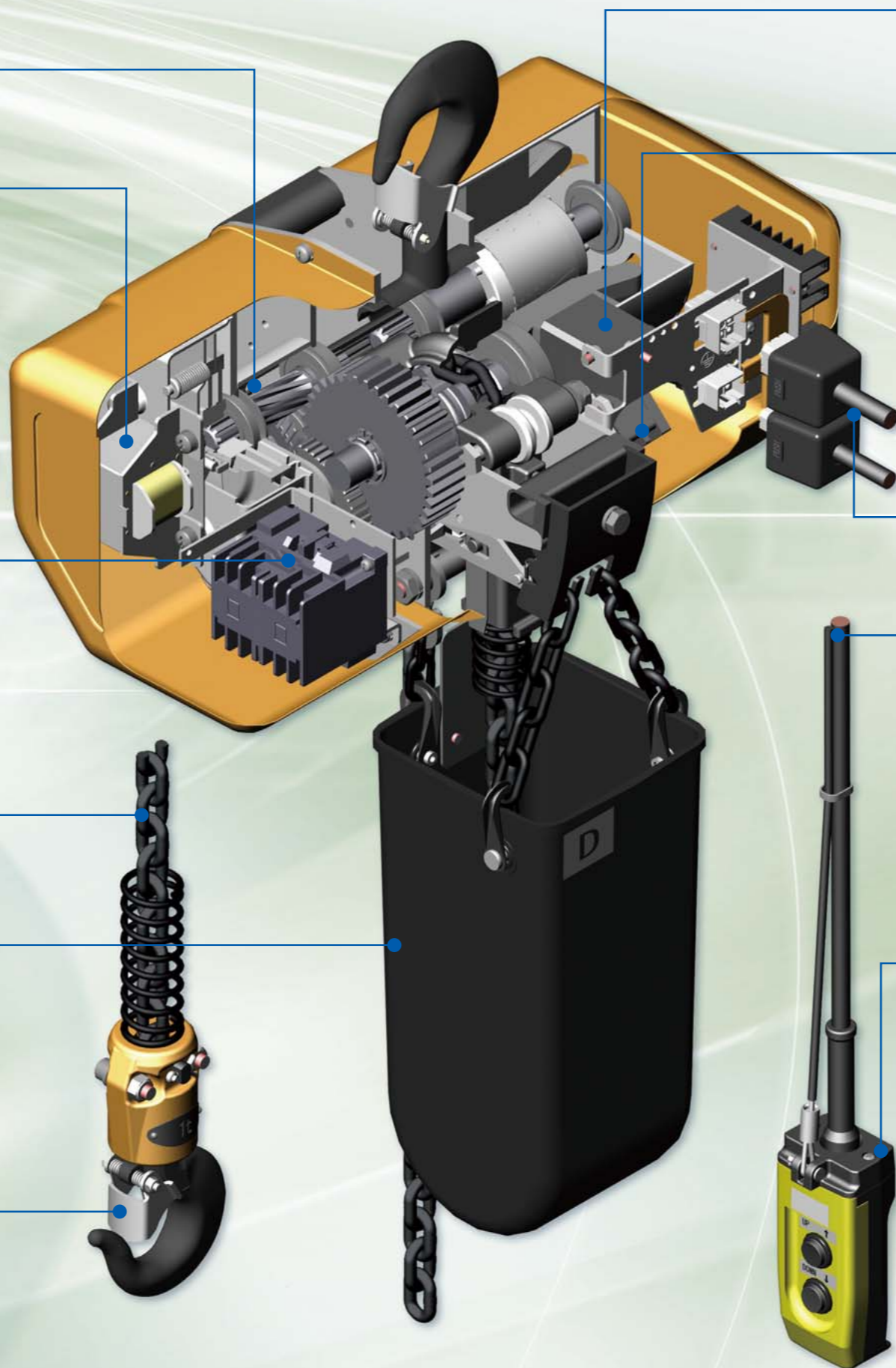

REVERSE PHASE INSPECTION RELAY **S F**

cut control circuit when reverse phasing. Except the 3 phase models of 250 kg and 500 kg, and single phase models.

LIMIT SWITCH (Upper and Lower) **L S F**

interrupt motor power to prevent hook overtravel and hazardous condition such as chain kink.

AUXILIARY BRAKE SYSTEM **F**

F series hoists equipped with auxiliary brake.



PLUG-IN CABLES **L S F**

reduce maintenance time and installation.

PUSHBUTTON CABLE **L S F**

is molded with strain relief wire rope into one body. This assures easier and safer operation.

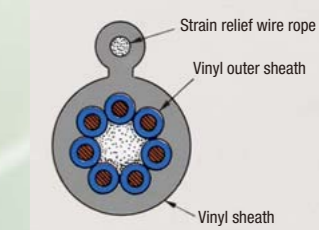

PUSHBUTTON SWITCH **L S F**

is rain-proof plastic for severe impact and corrosive atmosphere resistance and mechanically interlocked. The 24 volt control circuit reduce shock hazard to the operation.

HITACHI OVERLOAD LIMITER **L option S option F option**

Unique, patented over load protection device is available on all models upon request. U.S. PAT. 4103873 CANADA PAT. 1062232 Others

Not available for 1/6L, 1/6LH, 1/6LN, 1/6LNH

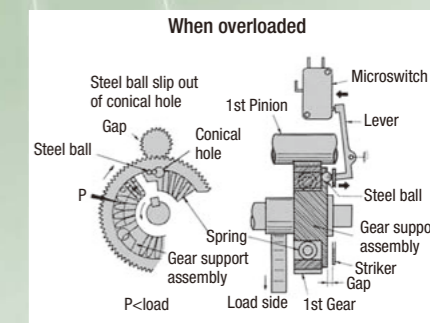

Outline

L series

S series

F series

Others

Conform with Essential Requirements Set Out in European Directives



CE MARKING MODEL L series **L** / S series **S** / F series **F**

LONG LIFE BRAKE UNIT **L S F**

Disk type Electro-Magnetic brake system for steady operation and long life.

AUTOMATIC ADJUSTING BRAKE **F**

are equipped with patented Automatic Adjusting Brake for easier maintenance and added safety. U.S. PAT. 3908802 Germany PAT. 2354044



ELECTRO-MAGNETIC CONTACTOR **L S F**

with mechanical-interlocking against line short by mechanical shock.

POWER CHAIN **L S F**

special (patented) alloy steel chain surface hardened for optimum strength and wear resistance. (DIN-5684-8)

CHAIN CONTAINER **L S F**

as standard part for safer operation.

LOWER HOOK **L S F**

is heat-treated and equipped with safety latch and 360° swivelling.

TRANSFORMER

Fuse is built in a primary side to prevent overheat.

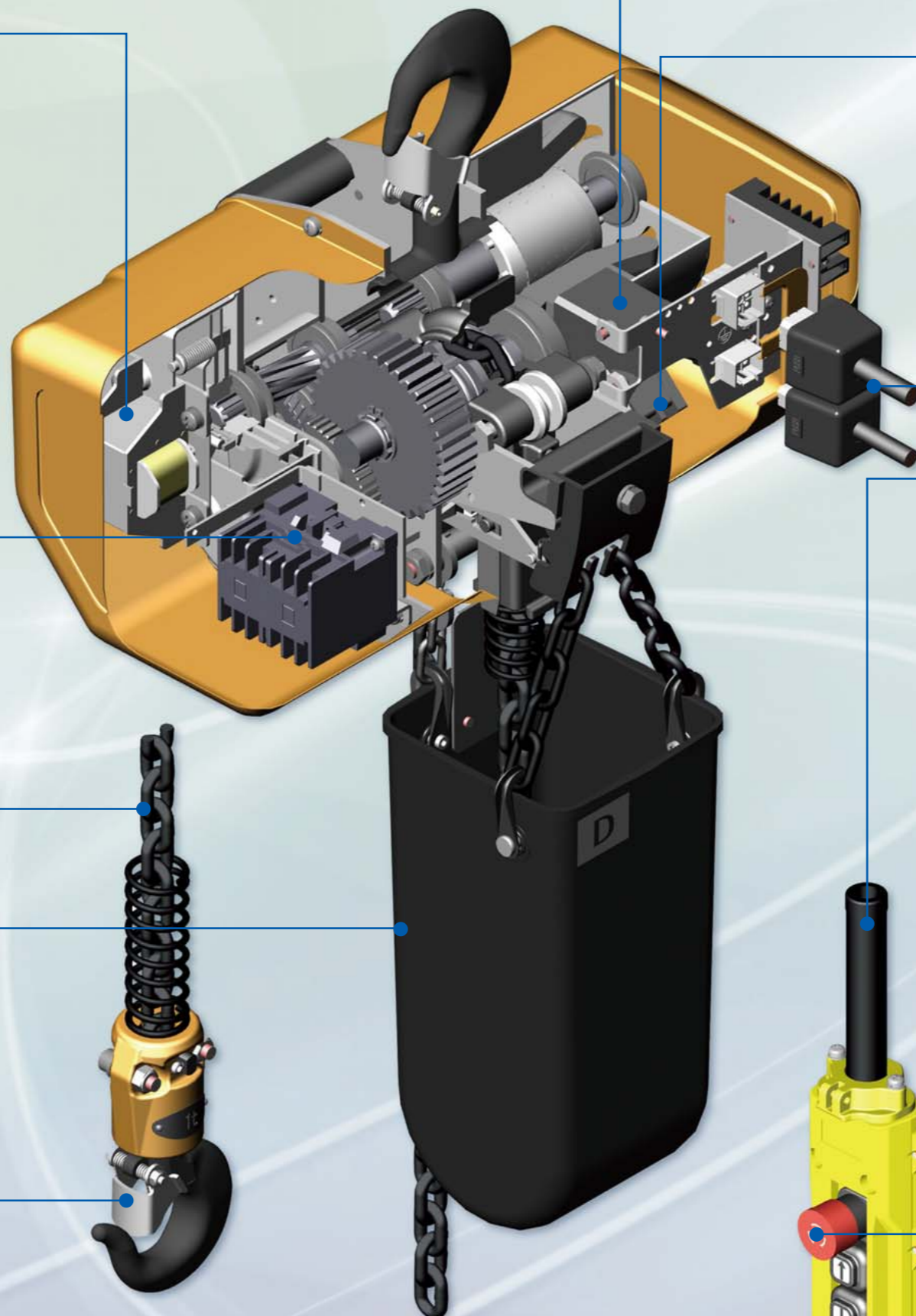
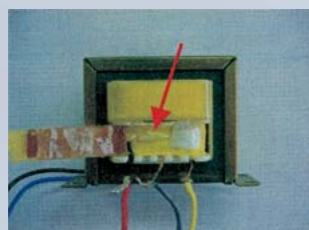

REVERSE PHASE INSPECTING RELAY **S F**

cut control circuit when reverse phasing. Except the 3 phase models of 250 kg and 500 kg, and single phase models.

LIMIT SWITCH (Upper and Lower) **L S F**

interrupt motor power to prevent hook overtravel and hazardous condition such as chain kink.

AUXILIARY BRAKE SYSTEM **F**

F series hoists equipped with auxiliary brake.



PLUG-IN CABLES **L S F**

reduce maintenance time and installation.

PUSHBUTTON CABLE **L S F**

is molded with strain relief wire rope into one body. This assures easier and safer operation.

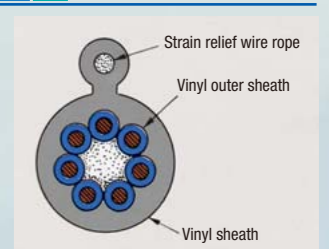

PUSHBUTTON SWITCH **L S F**

is rain-proof plastic for severe impact and corrosive atmosphere resistance and mechanically interlocked. The 24 volt control circuit reduce shock hazard to the operation.

● EMERGENCY STOP BUTTON

The chain hoist can be stopped in emergency cases that are caused by overdrive or erroneous operation.



HITACHI OVERLOAD LIMITER **L S F**

Unique, patented over load protection device is available on all models upon request. U.S. PAT. 4103873 CANADA PAT. 1062232 Others

Not available for 1/6L, 1/6LH, 1/6LN, 1/6LNH

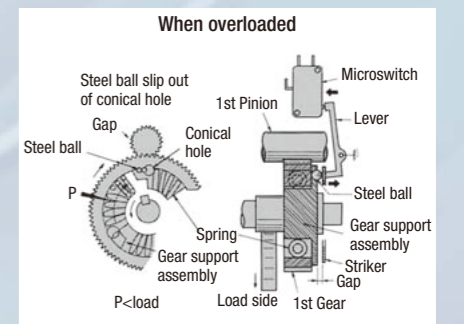

L series

Electric chain hoist

Suspension type

Single speed model

Dual speed model

Single phase model



HIGHER DURABILITY

- The load rating is 40% ED* which is a significant improvement over other previous models.
*L model

EASY SLINGING WORK

- The new hook allows for easy slinging work with the wide hook dimension.

Specifications table

SINGLE SPEED (3 PHASE)

L(H)		1/6L (H)*	1/4L (H)	1/2L (H)
Model Name				
Rated Load (kg)		150	250	500
Rating (%ED)		40		
Max.Starting Frequency (Starts/h)		240		
Hoisting Speed (m/min)	50Hz	14.4	10	7.2
	60Hz	17	12	8.5
Hook Dimensions (mm)		27		

*without overload limiter device

SINGLE PHASE

LS(H)		1/4LS (H)	1/2LS (H)
Model Name			
Rated Load (kg)		250	500
Rating (%ED)		25	
Max.Starting Frequency (Starts/h)		150	
Hoisting Speed (m/min)	50Hz	5.0	3.6
	60Hz	6.0	4.3
Hook Dimensions (mm)		27	

DUAL SPEED (3 PHASE)

LN(H)		1/6LN (H)*	1/4LN (H)	1/2LN (H)
Model Name				
Rated Load (kg)		150	250	500
Rating (%ED)		30		
Max.Starting Frequency (Starts/h)		180		
Hoisting Speed (m/min)	50Hz	14.4/3.6	10/2.5	7.2/1.8
	60Hz	17/4.3	12/3.0	8.5/2.1
Hook Dimensions (mm)		27		

*without overload limiter device

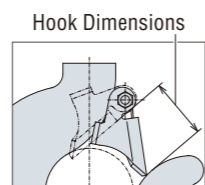

HIGHER SAFETY

- The new chain container next to the main body of the hoist prevents unnecessary movement of the chain container and Lower hook doesn't touch the chain container.
- The new Hook Latch has a claw. The claw grips on to the hook securely.

2-point Pushbutton Switch type

Dimensions

SINGLE SPEED

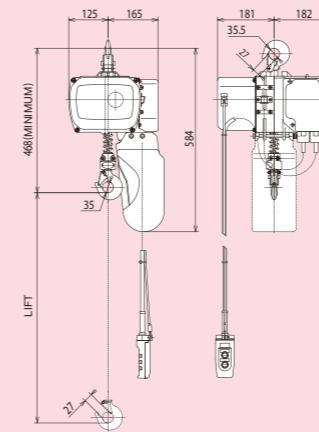

DUAL SPEED

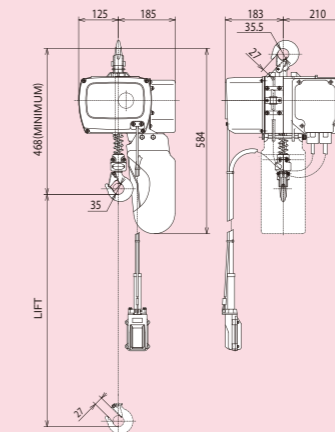

SINGLE PHASE

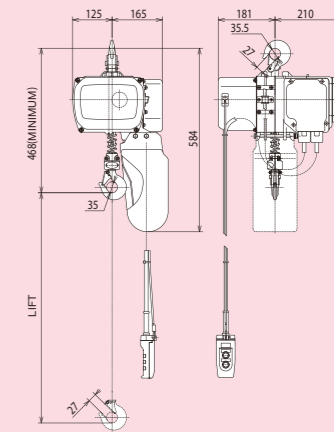

Specifications table

Model Name		1/6L,1/4L,1/2L	1/6LH,1/4LH,1/2LH	1/6LN,1/4LN,1/2LN	1/6LNH,1/4LNH,1/2LNH	1/4LS,1/2LS	1/4LSH,1/2LSH
Lift (m)		3	6	3	6	3	6
	Falls		1		1		1
Link Chain	Dia.	6.3		6.3		6.3	
	Pitch	19.1		19.1		19.1	
	Approx. Weight (kg)	32	35	35	38	34	37

3-point Pushbutton Switch type

Dimensions

SINGLE SPEED

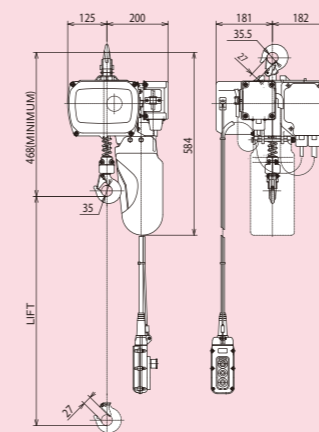

DUAL SPEED

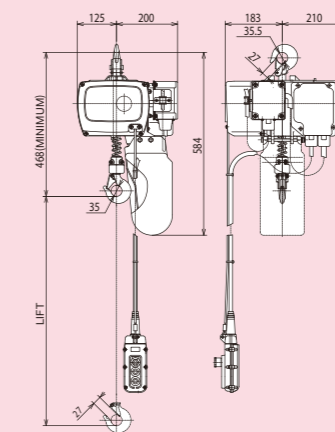

SINGLE PHASE

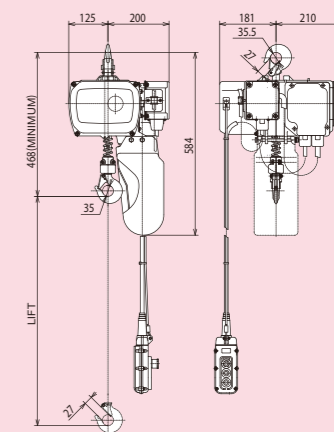

Specifications table

Model Name		1/6L,1/4L,1/2L	1/6LH,1/4LH,1/2LH	1/6LN,1/4LN,1/2LN	1/6LNH,1/4LNH,1/2LNH	1/4LS,1/2LS	1/4LSH,1/2LSH
Lift (m)		3	6	3	6	3	6
	Falls		1		1		1
Link Chain	Dia.	6.3		6.3		6.3	
	Pitch	19.1		19.1		19.1	
	Approx. Weight (kg)	33	36	36	39	35	38

S series

Electric chain hoist

Suspension type

Single speed model

Dual speed model

Single phase model



Specifications table

SINGLE SPEED (3 PHASE)

S(H)		1S(H)	2S(H)	3S(H)	5S(H)
Model Name		1S(H)	2S(H)	3S(H)	5S(H)
Rated Load	(kg)	1,000	2,000	3,000	5,000
Standard Lift	(m)	3(6)			
Hoisting Speed	50Hz	4.6	2.3	1.5	0.9
	60Hz	5.5	2.8	1.8	1.1
Motor Output	50Hz	0.8	0.8	0.8	0.8
	60Hz	1.0	1.0	1.0	1.0
Link Chain	Dia. (mm)	φ7.1	φ7.1	φ7.1	φ7.1
	No. of	1	2	3	5
Rating		25% ED			
Power Cord Length		5m			

DUAL SPEED (3 PHASE)

SN(H)		1SN(H)	2SN(H)
Model Name		1SN(H)	2SN(H)
Rated Load	(kg)	1,000	2,000
Standard Lift	(m)	3(6)	
Hoisting Speed	50Hz	4.6/1.2	2.3/0.6
	60Hz	5.5/1.4	2.8/0.7
Motor Output	50Hz	0.8/0.2	0.8/0.2
	60Hz	1.0/0.25	1.0/0.25
Link Chain	Dia. (mm)	φ7.1	φ7.1
	No. of Falls	1	2
Rating		20/10% ED	
Power Cord Length		5m	

SINGLE PHASE

SS(H) ₂ , S(H) ₁		1S(H) ₁	2S(H) ₁
Model Name		1S(H) ₁	2S(H) ₁
Rated Load	(kg)	1,000	2,000
Standard Lift	(m)	3(6)	
Hoisting Speed	50Hz	2.3	1.1
	60Hz	2.8	1.4
Motor Output	50Hz	0.4	0.4
	60Hz	0.5	0.5
Link Chain	Dia. (mm)	φ7.1	φ7.1
	No. of Falls	1	2
Rating		20% ED	
Power Cord Length		5m	

All dimensions and specifications are subject to change without notice.

Suspension type

Dimensions

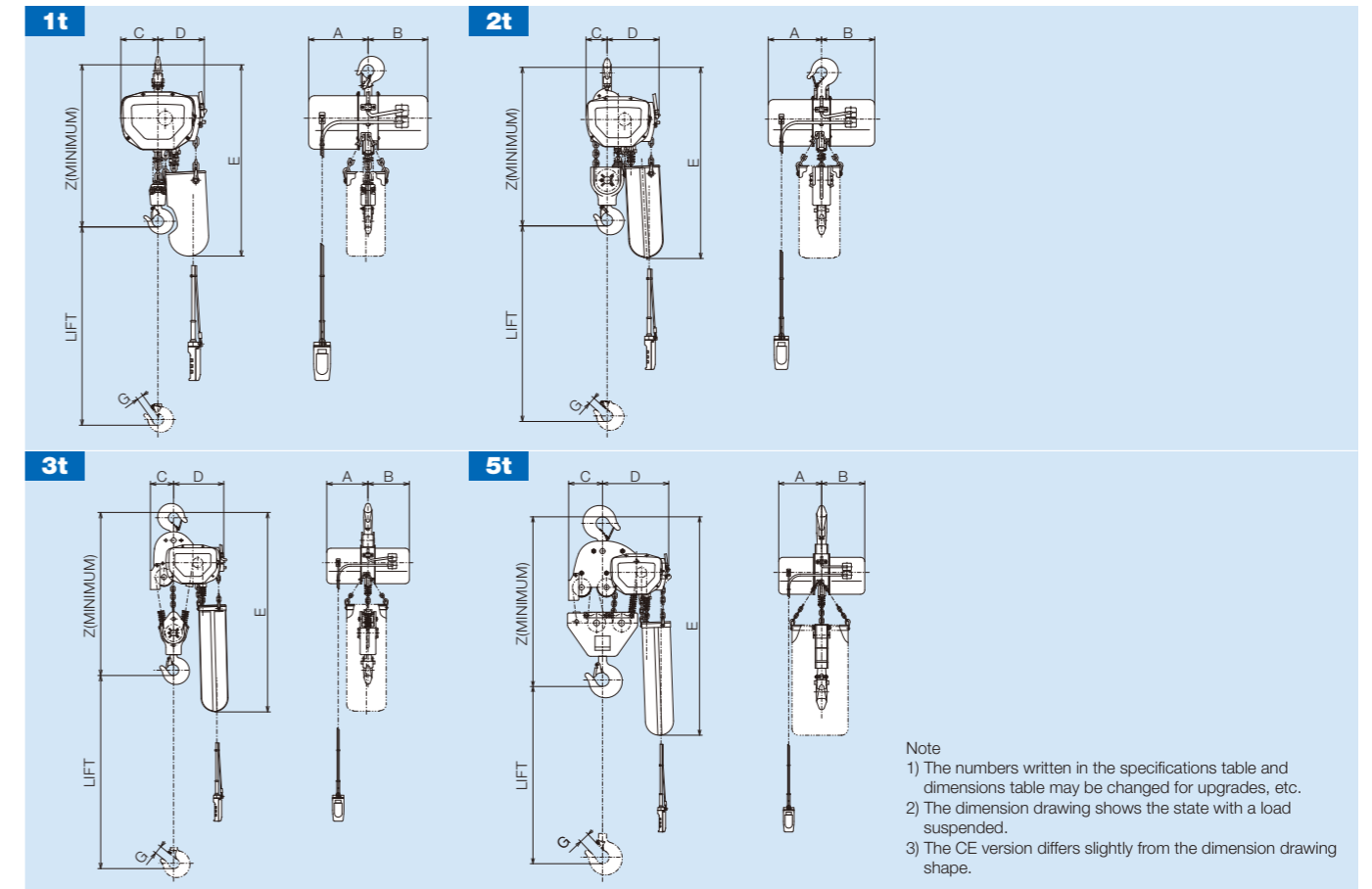

Specifications table

SINGLE SPEED (3 PHASE)

Model Name	1S	1SH	2S	2SH	3S	3SH	5S	5SH
Rated Load	1,000		2,000		3,000		5,000	
Dimensions	Z	540	665		800		895	
	A	216	216		216		216	
	B	216	216		216		216	
	C	135	90		125		175	
	D	170	215		270		340	
	D'(CE)	170	215		270		340	
	E	680	705	775	835	1,050	1,065	1,095
G	23	26		42		48		
Approx. Weight	37	42	49	59	61	72	88	105

All dimensions and specifications are subject to change without notice.

DUAL SPEED (3 PHASE)

Model Name	1SN	1SNH	2SN	2SNH
Rated Load	1,000		2,000	
Dimensions	Z	550	665	
	A	216	216	
	B	246	246	
	C	135	90	
	D	170	215	
	D'(CE)	170	215	
	E	680	705	775
G	23	26		
Approx. Weight	42	47	54	64

SINGLE PHASE

Model Name	1S1	1SH1	2S1	2SH1
Rated Load	1,000		2,000	
Dimensions	Z	540	665	
	A	246	246	
	B	246	246	
	C	135	90	
	D	170	215	
	D'(CE)	170	215	
	E	680	705	775
G	23	26		
Approx. Weight	39	44	51	61

All dimensions and specifications are subject to change without notice.

With motorized trolley-ET

This can be combined with a 4-point or 6-point pushbutton and used as a motorized trolley or overhead traveling crane.

Dimensions

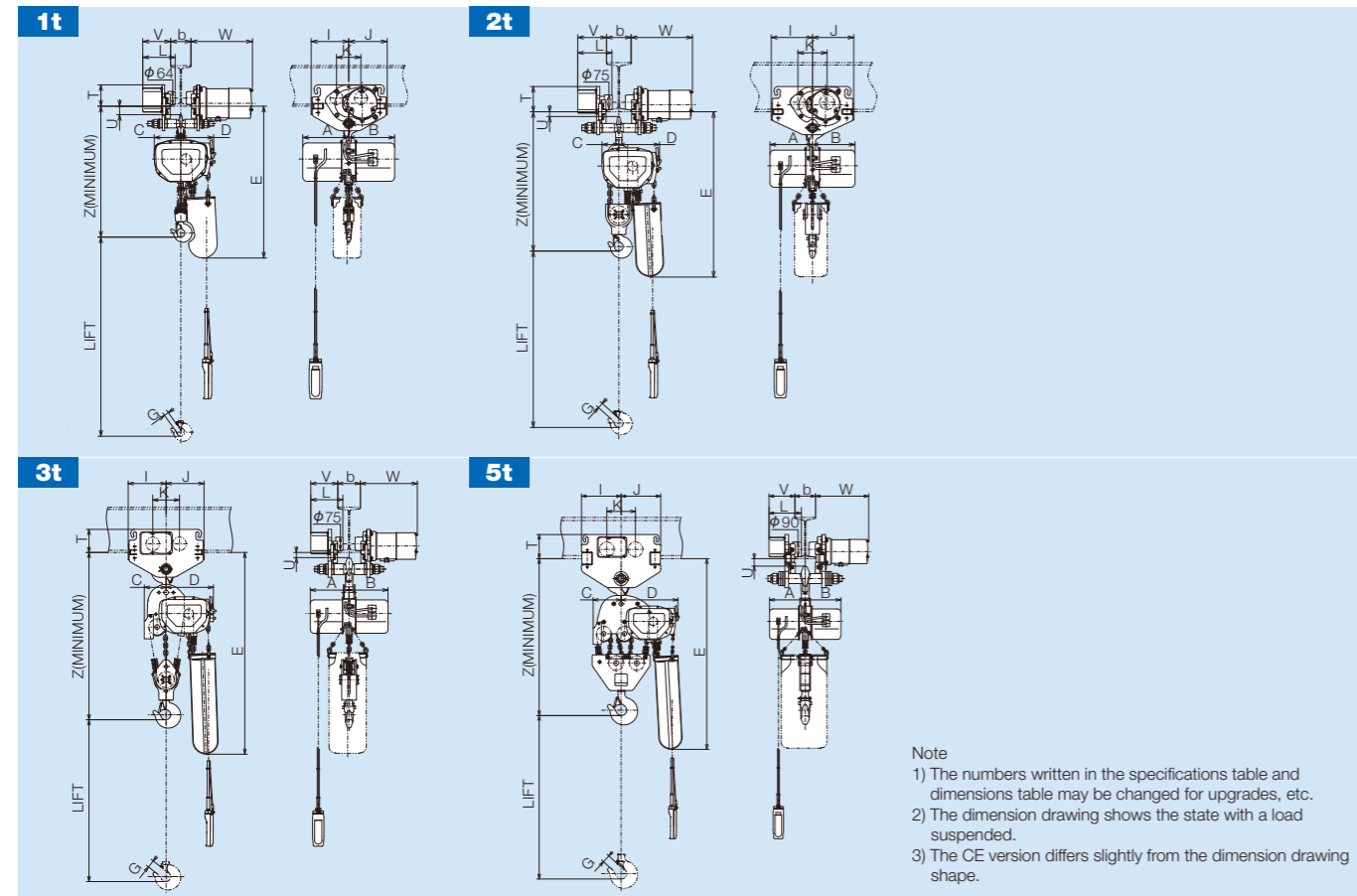

- Note
- 1) The numbers written in the specifications table and dimensions table may be changed for upgrades, etc.
 - 2) The dimension drawing shows the state with a load suspended.
 - 3) The CE version differs slightly from the dimension drawing shape.

Specifications table

Chain Hoist Model Name	1S(H)	1SN(H)	2S(H)	2SN(H)	3S(H)	5S(H)	
Trolley Type	1ET		2ET		3ET	5ET	
Rated Load (kg)	1,000		2,000		3,000	5,000	
Dimensions (mm)	Z	610	620	721	721	862	984
	A	216	216	216	216	216	216
	B	216	246	216	246	216	216
	C	135	135	90	90	125	175
	D	170	170	215	215	270	340
	D'(CE)	170	170	215	215	270	340
	E	750	750	770(840)		910(1,125)	1,170(1,200)
	G	23	23	26	26	42	48
	I	185		210		210	240
	J	190		210		210	240
	K	120		148		148	173
	L	182		200		203	219
	T	110		140		140	156
	U	38		18		16	34
V	159		172		175	181	
W	303		313		316	323	
Min. Curve Radius (m)	1.5		1.8		2.0	3.0	
Applicable Beam Width b (mm)	75-125		100-150		125-175	125-175	
Approx. Weight (kg)	75(80)	80(85)	101(111)	106(116)	121(132)	174(191)	

All dimensions and specifications are subject to change without notice.

Motorized trolley specifications table

Series Name	ET series				ST series		
Model Name	1ET	2ET	3ET	5ET	1ST	2ST	3ST
Working Load Limit (kg)	1,000	2,000	3,000	5,000	1,000	2,000	3,000
Traveling Speed (m/min)	50Hz	10.5(21)			10.5		
	60Hz	12.5(25)			12.5		
Motor Output (kW)	50Hz	0.14(0.27)		0.3(0.6)	0.07	0.14	0.2
	60Hz	0.16(0.32)		0.35(0.7)	0.08	0.16	0.24
Applicable Beam Width b (mm)	75-125	100-150		125-175	75-125	100-150	
Rating	25%ED						

With motorized trolley-ST

This can be combined with a 4-point or 6-point pushbutton and used as a motorized trolley or overhead traveling crane.

Dimensions

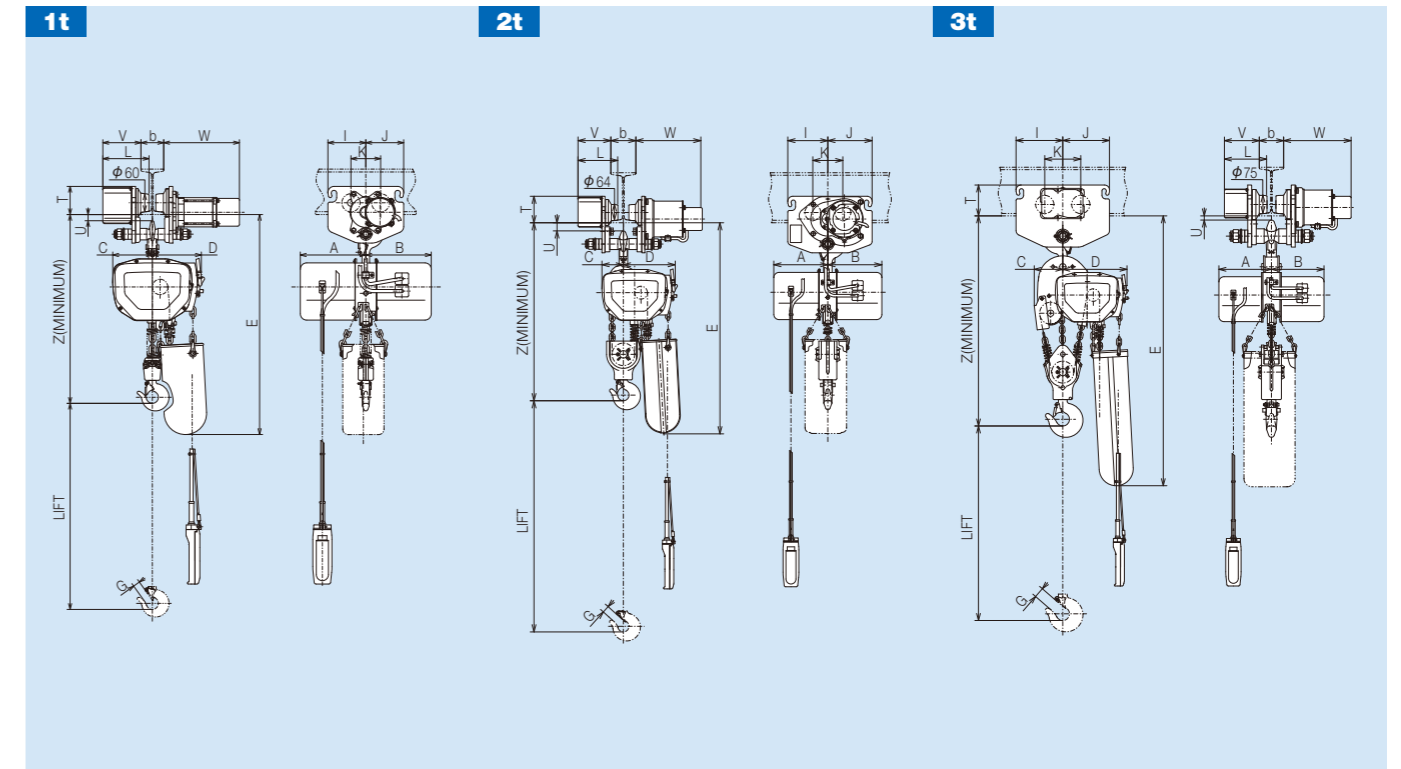

Specifications table

Chain Hoist Model Name	1S(H)	1SN(H)	2S(H)	2SN(H)	3S(H)	
Trolley Type	1ST		2ST		3ST	
Rated Load (kg)	1,000		2,000		3,000	
Dimensions (mm)	Z	590	590	719	719	852
	A	216	216	216	216	216
	B	216	246	216	246	216
	C	135	135	90	90	125
	D, D'(CE)	170	170	215	215	270
	E	730	730	772(842)		900(1,115)
	G	23	23	26	26	42
	I	125		160		192
	J	125		177		192
	K	98		120		148
	L	156		163		180
	T	101		119		140
	U	18		19		5
	V	130		135		145
W	255		270		280	
Min. Curve Radius (m)	1.8		2.5		3.0	
Applicable Beam Width b (mm)	75-100		100-150		100-150	
Approx. Weight (kg)	60(65)	65(70)	86(96)	91(101)	109(120)	

All dimensions and specifications are subject to change without notice.

With chain driven trolley-BC

The electric chain hoist with chain driven trolley is suitable for relatively heavy loads not transported a long distance.

■ Dimensions

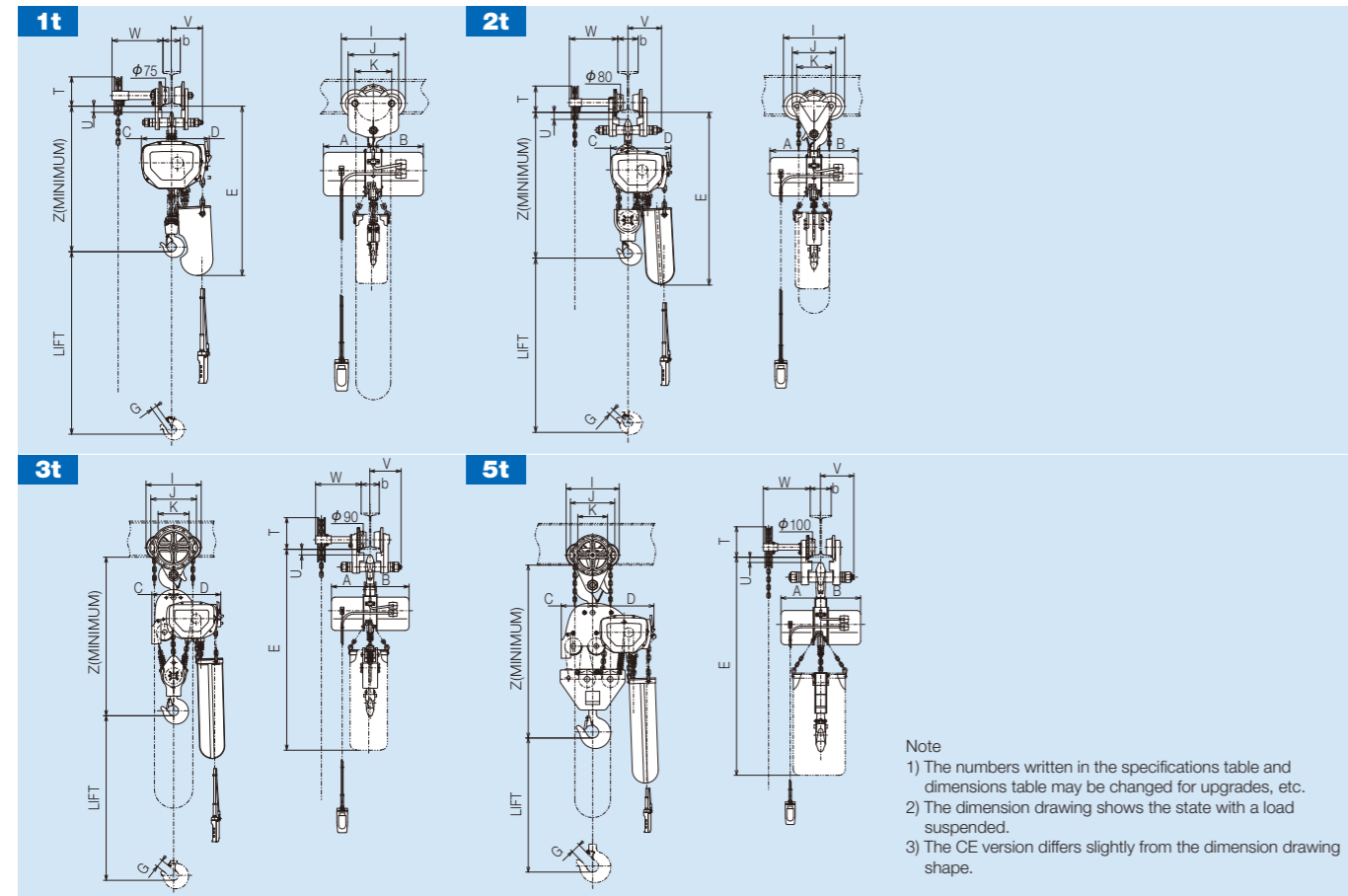

- Note
- 1) The numbers written in the specifications table and dimensions table may be changed for upgrades, etc.
 - 2) The dimension drawing shows the state with a load suspended.
 - 3) The CE version differs slightly from the dimension drawing shape.

■ Specifications table

Chain Hoist Model Name	1S(H)	1SN(H)	2S(H)	2SN(H)	3SH	5SH	
Trolley type	1BC(H)		2BC(H)		3BCH	5BCH	
Rated Load (kg)	1,000		2,000		3,000	5,000	
Dimensions (mm)	Z	585	585	723	723	866	980
	A	216	216	216	216	216	216
	B	216	246	216	246	216	216
	C	135	135	90	90	125	175
	D	170	170	215	215	270	340
	D'(CE)	170	170	215	215	270	340
	E	740	740	775(845)		1,130	1,190
	G	23	23	26	26	42	48
	I	277		300		306	319
	J	218		213		240	262
	K	158		169		172	177.2
	T	131		143		191	194
	U	23		22		21	30
	V	135		165		173	200
	W	220		236		252	284
Min. Curve Radius (m)	1.2		1.5		1.5	2.4	
Applicable Beam Width b (mm)	75-125		100-150		100-150	125-175	
Approx. Weight (kg)	58(66)	63(71)	73(86)	78(91)	116	161	

With manual driven trolley-BP

The electric chain hoist with manual driven trolley is suitable for relatively light loads transported a short distance.

■ Dimensions

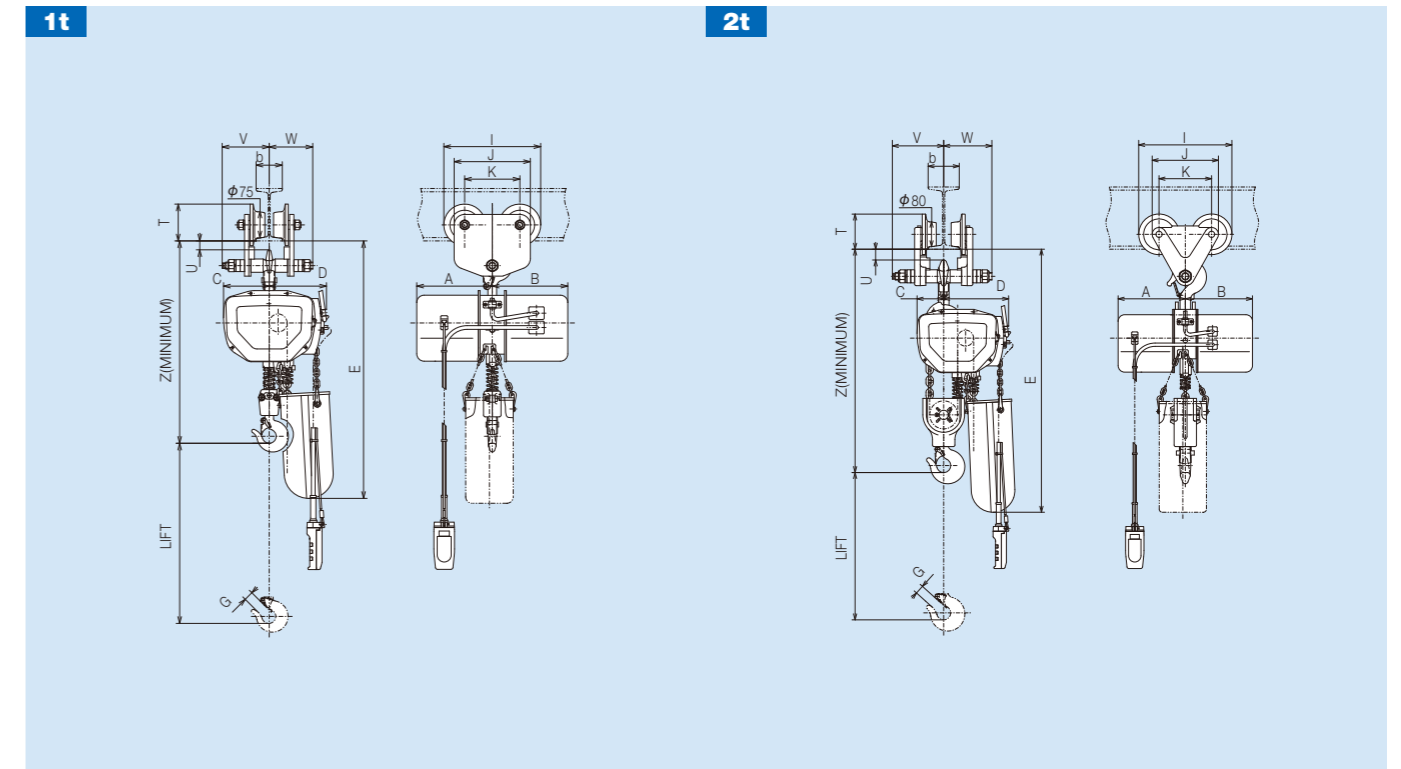

■ Specifications table

Chain Hoist Model Name	1S(H)	1SN(H)	2S(H)	2SN(H)	
Trolley type	1BP		2BP		
Rated Load (kg)	1,000		2,000		
Dimensions (mm)	Z	595	595	723	723
	A	216	216	216	216
	B	216	246	216	246
	C	135	135	90	90
	D	170	170	215	215
	D'(CE)	170	170	215	215
	E	740	740	775(845)	
	G	23	23	26	26
	I	277		300	
	J	199		213	
	K	139		169	
	T	110		128	
	U	23		22	
	V	135		165	
	W	125		155	
Min. Curve Radius (m)	1.2		1.5		
Applicable Beam Width b (mm)	75-125		100-150		
Approx. Weight (kg)	52(57)	57(62)	66(76)	71(81)	

■ Chain driven trolley, manual driven trolley specifications table

Classification	Chain driven trolley				Manual driven trolley	
Model Name	1BC(H)	2BC(H)	3BCH	5BCH	1BP	2BP
Working Load Limit (kg)	1,000	2,000	3,000	5,000	1,000	2,000
Standard Lift (m)	3(6)	3(6)	6	6	—	—
Min. Curve Radius (m)	1.2	1.5	1.5	2.4	1.2	1.5
Applicable Beam Width b (mm)	75-125	100-150		125-175	75-125	100-150

For a crane that uses a chain or manual driven trolley for transverse movement and an electric motor for travel, please purchase a 4PB(H)-C, 4PBN(H)-C type wiring unit (See page 23).

F series

Electric chain hoist

Suspension type

Single speed model

Dual speed model



Specifications table

SINGLE SPEED (3 PHASE)

F(H)								
Model Name	1F(H)	2F(H)	3F(H)	5F(H)	10FH	15FH	20FH	
Rated Load (kg)	1,000	2,000	3,000	5,000	10,000	15,000	20,000	
Standard Lift (m)	3(6)			6				
Hoisting Speed (m/min)	50Hz	7.1	6.8	4.1	2.8	2.8	1.8	1.4
	60Hz	8.5	8.2	4.9	3.3	3.3	2.2	1.6
Motor Output (kW)	50Hz	1.3	2.4		2.4×2			
	60Hz	1.6	2.9		2.9×2			
Link Chain	Dia. (mm)	φ 7.1			φ 10			
	No. of Falls	1	1	2	3	4	6	8
Rating	30% ED							
Power Cord Length	5m							

DUAL SPEED (3 PHASE)

FN(H)						
Model Name	2FN(H)	3FN(H)	5FN(H)	10FNH	15FNH	
Rated Load (kg)	2,000	3,000	5,000	10,000	15,000	
Standard Lift (m)	3(6)			6		
Hoisting Speed (m/min)	50Hz	6.8/1.7	4.0/1.0	2.8/0.7	2.8/0.7	1.8/0.45
	60Hz	8.2/2.1	4.8/1.2	3.3/0.8	3.3/0.8	2.2/0.55
Motor Output (kW)	50Hz	2.4/0.6		2.4/0.6×2		
	60Hz	2.9/0.7		2.9/0.7×2		
Link Chain	Dia. (mm)	φ 10				
	No. of Falls	1	2	3	4	6
Rating	20% ED					
Power Cord Length	5m					

All dimensions and specifications are subject to change without notice.

Suspension type

Fseries

Dimensions

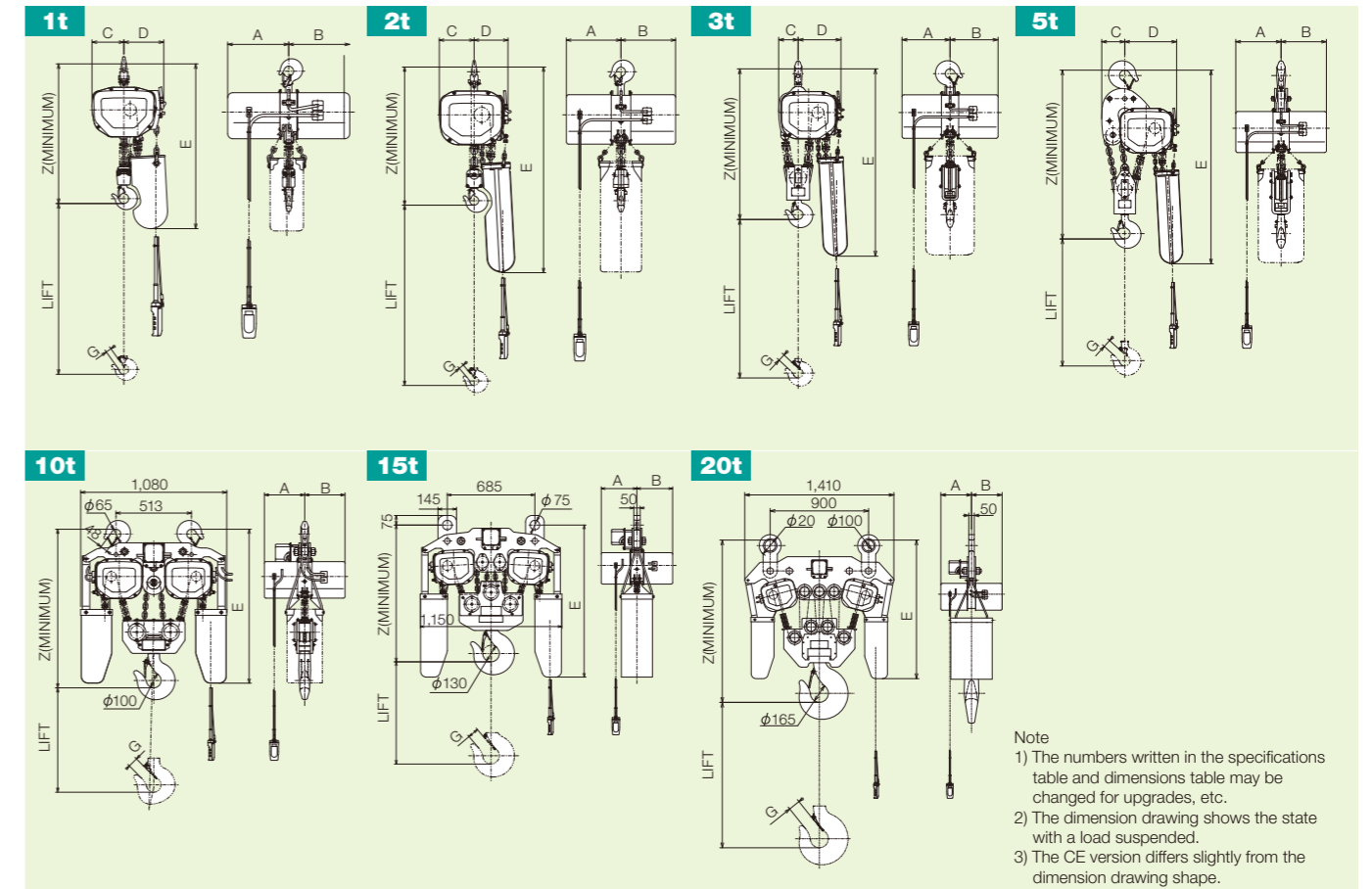

Note
 1) The numbers written in the specifications table and dimensions table may be changed for upgrades, etc.
 2) The dimension drawing shows the state with a load suspended.
 3) The CE version differs slightly from the dimension drawing shape.

Specifications table

SINGLE SPEED (3 PHASE)

Model Name	1F	1FH	2F	2FH	3F	3FH	5F	5FH	10FH	15FH	20FH	
Rated Load (kg)	1,000		2,000		3,000		5,000		10,000	15,000	20,000	
Dimensions (mm)	Z	540		670		830		1,020	1,060	1,235	1,440	
	A	250		280		280		280	280	280	280	
	B	250		280		280		280	280	280	280	
	C	135		175		120		145	—	—	—	
	D	170		170		245		330	—	—	—	
	E	680		845	1,060	1,090	1,100	1,295	1,305	1,040	1,280	1,400
	G	23		26		42		48	68	86	108	
Approx. Weight (kg)	42	47	81	87	103	113	140	152	330	490	690	

All dimensions and specifications are subject to change without notice.

DUAL SPEED (3 PHASE)

Model Name	2FN	2FNH	3FN	3FNH	5FN	5FNH	10FNH	15FNH	
Rated Load (kg)	2,000		3,000		5,000		10,000	15,000	
Dimensions (mm)	Z	680		830		1,020	1,060	1,235	
	A	280		280		280	280	280	
	B	330		330		330	330	330	
	C	175		120		145	—	—	
	D	170		245		330	—	—	
	E	845	1,060	1,090	1,100	1,295	1,305	1,040	1,280
	G	26		42		48		68	86
Approx. Weight (kg)	96	102	116	128	146	167	360	520	

All dimensions and specifications are subject to change without notice.

Outline

L series

S series

F series

Others

With motorized trolley-ET

This can be combined with a 4-point or 6-point pushbutton and used as a motorized trolley or overhead traveling crane.

Dimensions

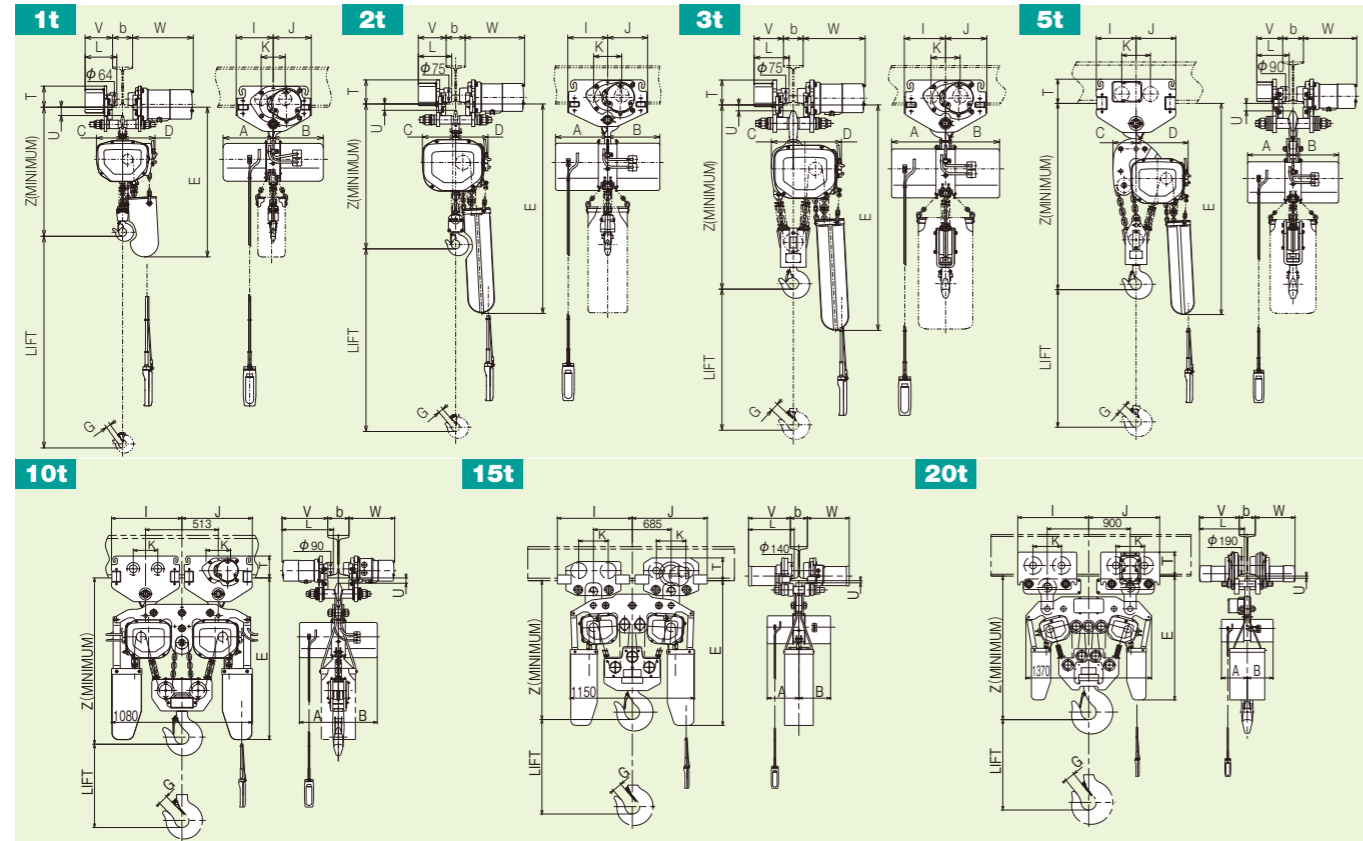

Note
 1) The numbers written in the specifications table and dimensions table may be changed for upgrades, etc.
 2) The dimension drawing shows the state with a load suspended.
 3) The CE version differs slightly from the dimension drawing shape.

Specifications table

Chain Hoist Model Name	1F(H)	2F(H)	2FN(H)	3F(H)	3FN(H)	5F(H)	5FN(H)	10FH	10FNH	15FH	15FNH	20FH					
Trolley Type	1ET	2ET	3ET	5ET	5ET×2	7.5ET×2	10ET×2										
Rated Load (kg)	1,000	2,000	3,000	5,000	10,000	15,000	20,000										
Z	610	731	736	892	892	1,112	1,112	1,150	1,152	1,150	1,152	1,210	1,212	1,210	1,212	1,520	1,515
A	250	280	280	280	280	280	280	280	280	280	280	280	280	280	280	280	280
B	250	280	330	280	330	280	330	280	330	280	330	280	330	280	330	280	330
C	135	185	185	120	120	145	145	—	—	—	—	—	—	—	—	—	—
D	170	170	170	245	245	330	330	—	—	—	—	—	—	—	—	—	—
E	750	945(1,125)	1,130(1,185)	1,410	1,410	1,130	1,130	1,265	1,265	1,265	1,265	1,375	1,375	1,375	1,375	1,375	1,375
G	23	26	26	42	42	48	48	68	68	86	86	108	108	108	108	108	108
I	185	210	210	240	240	500	500	663	663	663	663	770	770	770	770	770	770
J	190	210	210	240	240	500	500	663	663	663	663	770	770	770	770	770	770
K	120	148	148	173	173	173	173	260	260	260	260	309	309	309	309	309	309
L	182	200	203	219	219	362	362	434	434	434	434	511	511	511	511	511	511
T	110	140	140	156	156	158	156	158	156	205	203	205	203	205	203	280	285
U	38	18	16	34	34	32	34	32	34	15	17	15	17	23	18	23	18
V	159	172	175	181	181	323	323	401	401	401	401	455	455	455	455	455	455
W	303	313	316	323	323	323	323	401	401	401	401	455	455	455	455	455	455
Min. Curve Radius (m)	1.5	1.8	2.0	3.0	3.0	5.0	5.0	5.0	5.0	5.0	5.0	Straight	Straight	Straight	Straight	Straight	Straight
Applicable Beam Width b (mm)	75-125	100-150	100-150	125-175	125-175	150	175	150	175	150	175	150	175	150	175	175	190
Approx. Weight (kg)	80(85)	132(139)	147(154)	161(175)	176(190)	217(238)	232(253)	502	532	860	890	1,490	1,490	1,490	1,490	1,490	1,490

All dimensions and specifications are subject to change without notice.

With motorized trolley-ST

This can be combined with a 4-point or 6-point pushbutton and used as a motorized trolley or overhead traveling crane.

Dimensions

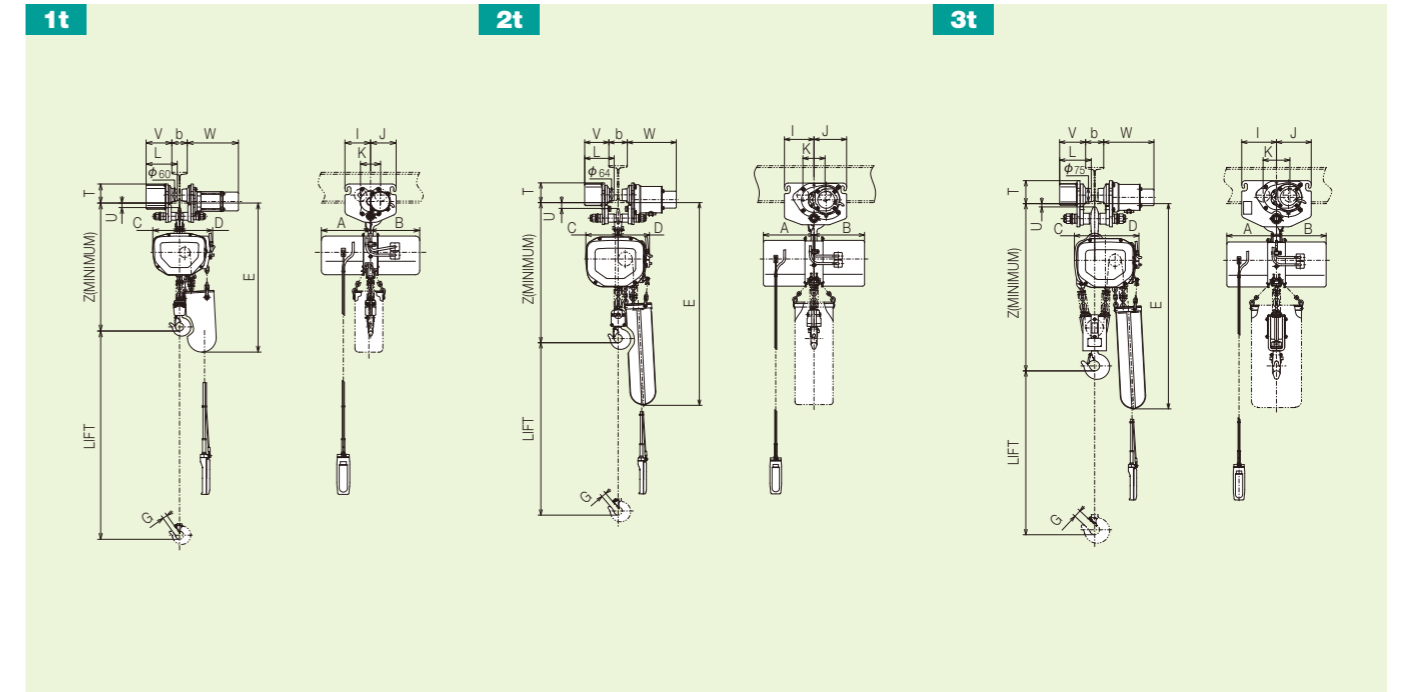

Specifications table

Chain Hoist Model Name	1F(H)	2F(H)	2FN(H)	3F(H)	3FN(H)
Trolley Type	1ST	2ST	2ST	3ST	3ST
Rated Load (kg)	1,000	2,000	2,000	3,000	3,000
Z	582	715	715	872	872
A	250	280	280	280	280
B	250	280	330	280	330
C	135	185	185	120	120
D	170	170	170	245	245
E	725	935(1,115)	935(1,115)	1,110(1,165)	1,110(1,165)
G	23	26	26	42	42
I	125	160	160	192	192
J	125	177	177	192	192
K	98	120	120	148	148
L	156	163	163	180	180
T	101	119	119	140	140
U	18	19	19	5	5
V	130	135	135	145	145
W	255	270	270	280	280
Min. Curve Radius (m)	1.8	2.5	2.5	3.0	3.0
Applicable Beam Width b (mm)	75-125	100-150	100-150	100-150	100-150
Approx. Weight (kg)	66(71)	117(124)	132(139)	140(161)	155(176)

Motorized trolley specifications table

Series Name	ET series							ST series		
Model Name	1ET	2ET	3ET	5ET	5ET×2	7.5ET×2	10ET×2	1ST	2ST	3ST
Working Load Limit (kg)	1,000	2,000	3,000	5,000	10,000	15,000	20,000	1,000	2,000	3,000
Travelling Speed (m/min)	10.5(21)			10.5			14	10.5		
	60Hz			12.5(25)			17	12.5		
Motor Output (kW)	0.14(0.27)		0.3(0.6)		0.3×2		0.7×2	0.07	0.14	0.2
	60Hz		0.35(0.7)		0.35×2		0.84×2	0.08	0.16	0.24
Applicable Beam Width b (mm)	75-125	100-150		125-175		150, 175	175, 190	75-125	100-150	
Rating	25%ED						40%ED	25%ED		

All dimensions and specifications are subject to change without notice.

With chain driven trolley-BC

The electric chain hoist with chain driven trolley is suitable for relatively heavy loads not transported a long distance.

Dimensions

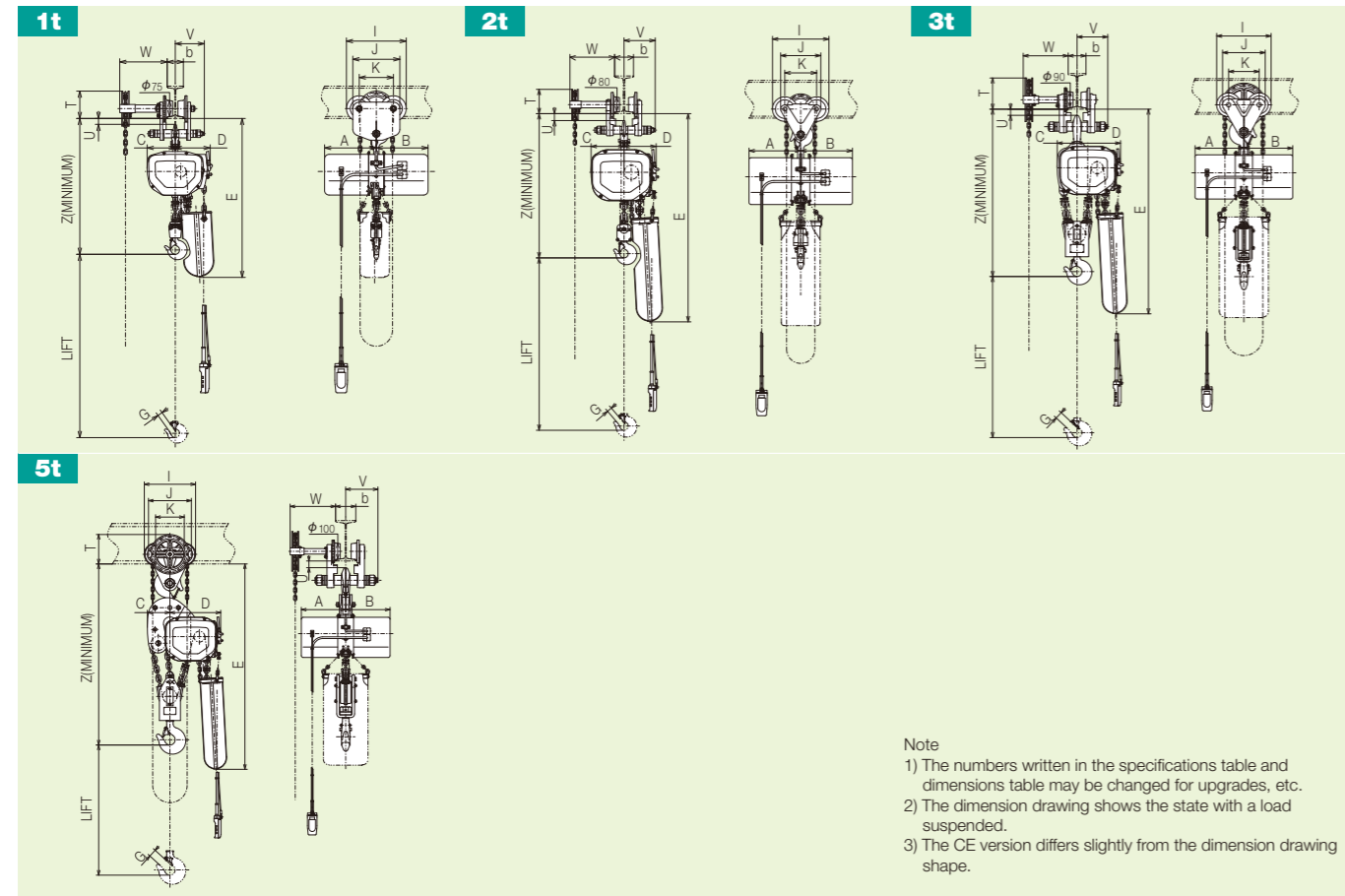

Note
 1) The numbers written in the specifications table and dimensions table may be changed for upgrades, etc.
 2) The dimension drawing shows the state with a load suspended.
 3) The CE version differs slightly from the dimension drawing shape.

Specifications table

Chain Hoist Model Name	1F(H)	2F(H)	2FN(H)	3FH	3FNH	5FH	5FNH
Trolley type	1BC(H)	2BC(H)		3BCH		5BCH	
Rated Load (kg)	1,000	2,000	2,000	3,000		5,000	
Dimensions (mm)	Z	595	717	717	896	896	1,105
	A	250	280	280	280	280	280
	B	250	280	330	280	330	280
	C	135	175	175	120	120	145
	D	170	170	170	245	245	330
	E	740	1,130	1,130	1,180	1,180	1,405
	G	23	26	26	42	42	48
	I	277	300		306		319
	J	218	213		240		262
	K	158	169		172		177.2
	L	—	—		—		—
	T	131	143		191		194
	U	23	22		21		30
	V	135	165		173		200
W	220	236		252		284	
Min. Curve Radius (m)	1.2	1.5		1.5		2.4	
Applicable Beam Width b (mm)	75–125	100–150		100–150		125–175	
Approx. Weight (kg)	63(71)	104(114)	120(129)	157	170	198	223

With manual driven trolley-BP

The electric chain hoist with manual driven trolley is suitable for relatively light loads transported a short distance.

Dimensions

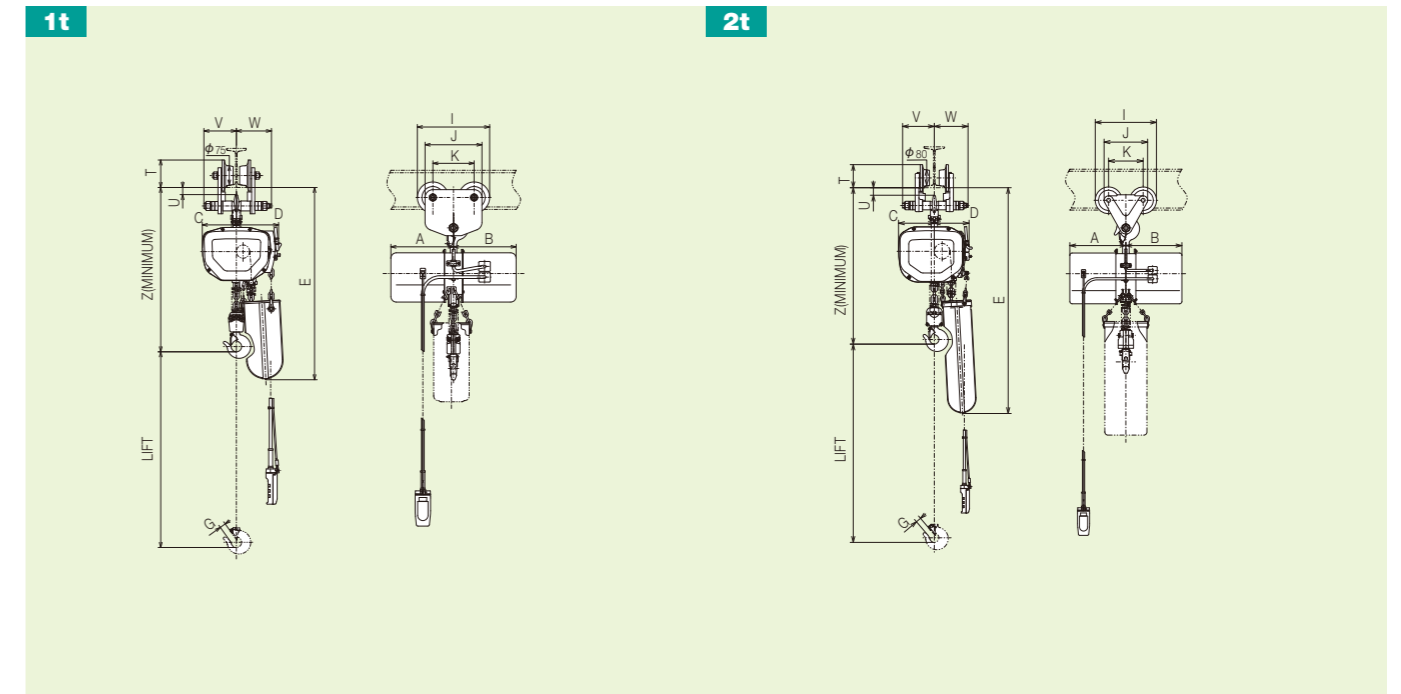

Specifications table

Chain Hoist Model Name	1F(H)	2F(H)	2FN(H)	
Trolley type	1BP	2BP		
Rated Load (kg)	1,000	2,000		
Dimensions (mm)	Z	595	717	717
	A	250	280	280
	B	250	280	330
	C	135	175	175
	D	170	170	170
	E	740	1,130	1,130
	G	23	26	26
	I	277	300	
	J	218	213	
	K	158	169	
	L	—	—	
	T	110	128	
	U	23	22	
	V	125	155	
W	135	165		
Min. Curve Radius (m)	1.2	1.5		
Applicable Beam Width b (mm)	75–125	100–150		
Approx. Weight (kg)	57(62)	97(104)	113(119)	

Chain driven trolley, manual driven trolley specifications table

Classification	Chain driven trolley				Manual driven trolley	
	1BC(H)	2BC(H)	3BCH	5BCH	1BP	2BP
Model Name	1,000	2,000	3,000	5,000	1,000	2,000
Working Load Limit (kg)	1,000	2,000	3,000	5,000	1,000	2,000
Standard Lift (m)	3(6)	3(6)	6	6	—	—
Min. Curve Radius (m)	1.2	1.5	1.5	2.4	1.2	1.5
Applicable Beam Width b (mm)	75–125	100–150		125–175	75–125	100–150

For a crane that uses a chain or manual driven trolley for transverse movement and an electric motor for travel, please purchase a 4PB(H)-C, 4PBN(H)-C type wiring unit (See page 23).

4-point pushbutton crane wiring unit

- This is a wiring unit for connecting to the crane electro-magnetic switch and the hoist main unit.
- Connection can be done simply by just attaching to the hoist main unit.
- A unique HITACHI operation cable with a single protective wire provides excellent operability and durability.
- The pushbutton is made of drip-proof hardened plastic.
- The pushbutton cable employs a one-touch outlet to allow it to be connected easily.

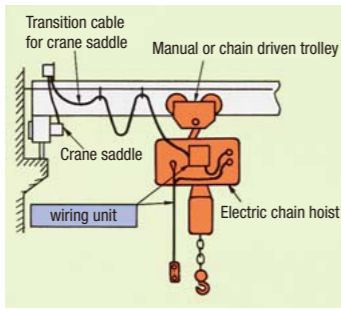

Specifications table

The product is a wiring unit that combines an electric chain hoist with an crane saddle for use with manual traverse (manual or chain driven trolley) and motorized travel 4-point pushbutton cranes.

For single speed models

Model Name	4PB-C	4PBH-C
Lift	3m	6m
Approx. Weight	3kg	3.5kg

For double speed models

Model Name	4PBN-C	4PBNH-C
Lift	3m	6m
Approx. Weight	3.5kg	4kg

Electro-magnetic switch unit with crane case

- This is the electro-magnetic switch unit with a case for girder operation (24V) for when a HITACHI electric chain hoist (with motorized trolley) is used in a crane girder system. (Applicable up to HITACHI crane saddle TLU_s-56 and TH_s-56)

- Install in a freely selected location of the girder system, and the transition cables for girder and trolley, and the power cable are connected to the terminal block.

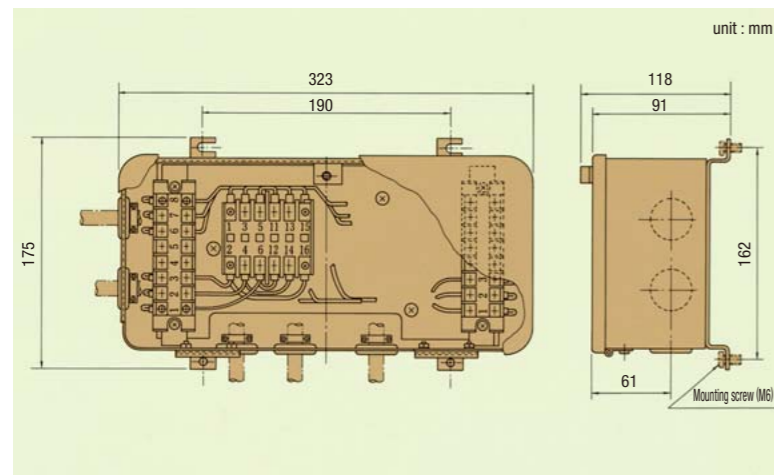
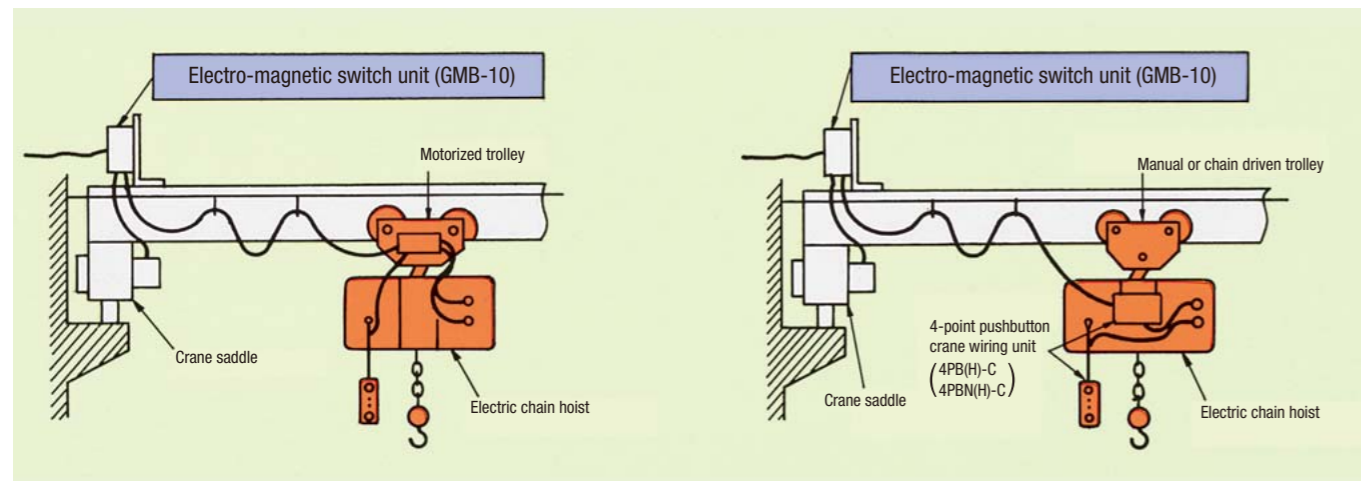

Specifications table

Model Name	GMB-10	
Electro-magnetic Contactor	Type	HMU-12
	Control Voltage	24V
	Current Capacity	10A
Approx. Weight	4kg	

Twin hook type electric chain hoist

The HITACHI twin hook type electric chain hoist is a two-chain, two-hook type with two chain hoists in the same sprocket axis. Since there is 1 chain hoist drive, the load is kept level during hoisting. This is optimal for long items that must be hoisted from 2 points and cargo that must be kept level.

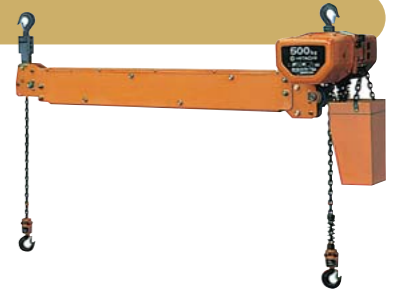

Basic specifications table

Model (main unit)	1/4SHT	1/2SHT	1SHT	1FHT	2FHT
Rated Load	125kg×2	250kg×2	500kg×2	500kg×2	1000kg×2
Standard Lift (m)	6				
Hoisting Speed (m/min)	50Hz	7.1	4.6	7.1	6.8
	60Hz	11	8.5	5.5	8.5
Traveling Speed (m/min)	10.5				
	12.5				
Hoisting Motor (kW)	50Hz	0.4	0.65	0.8	1.3
	60Hz	0.5	0.8	1.0	1.6
Traveling Motor (kW)	2				
	0.14				
Link Chain (dia./falls)	4				
	0.16				
Link Chain (dia./falls)			φ7.1×2		φ10×2

* A load must always be applied to the lower hook P side, so please inform HITACHI when a original sling will not be used.

Dimensions

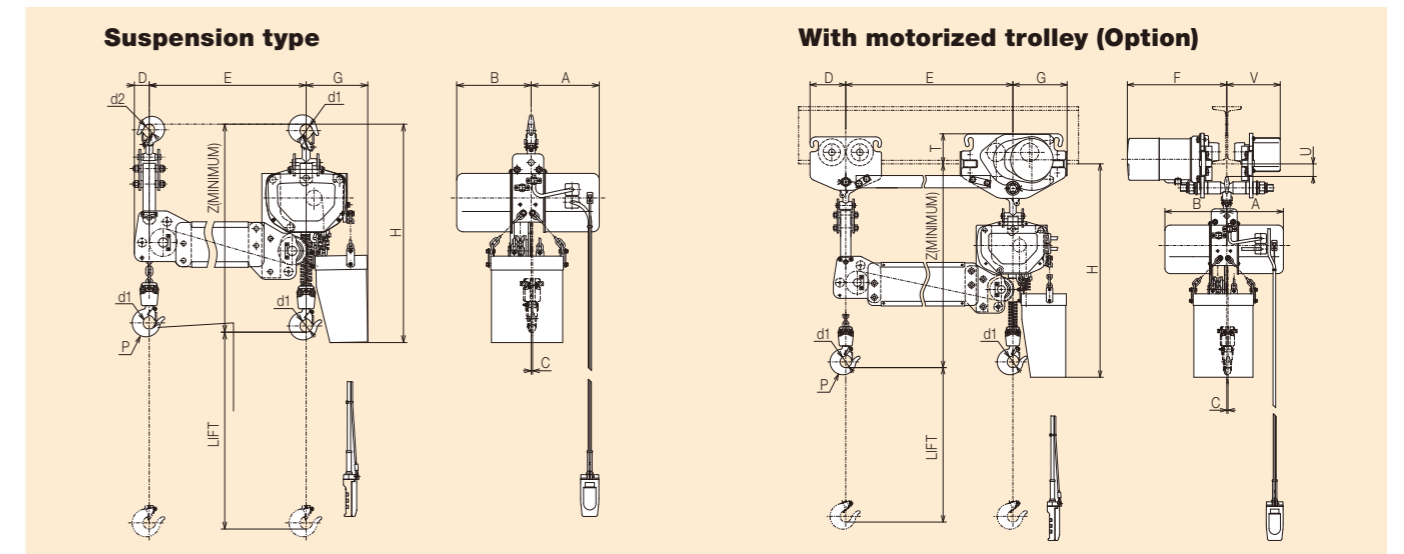

Specifications table

Chain Hoist Model Name	1/4SHT	1/2SHT	1SHT	1FHT	2FHT	
Trolley Type	1ET					
Dimensions (mm)	A	212		246	286	
	B	252		286	339	
	C	5		5	6	
	D	125(48)		125(48)	125(61)	
	φ d ₁	40		40	45	
	φ d ₂	35.5		35.5	40	
	E	500-2,000(50 Interval) The actual dimensions differ slightly.				
	F	341	353	366	341	353 366 363 375 388
	G	190(170)			190(170)	210(170)
	V	174	187	199	174	187 199 196 209 221
	T	110				
	U	38				
	With Motorized Trolley	H	837	836	834	837 836 834 992 989 980
Suspension	Z	744	743	741	744 743 741 877 874 865	
	H	765				
	Z	672				
Applicable Beam Width (mm)	75-125			75-125 100-150		

* The suspension type is shown in parentheses ().
* Only the straight rail is applicable to the trolley.

Optional power source electric chain hoist and trolley

When the power source specifications differ, the following power source products will be manufactured.

50Hz	240V
60Hz	230V, 380V, 440V, 460V

Electric chain hoist with the Hi-plated chain

This comes with a corrosion-resistant Hi-plated chain. The chain specifications and strength are those of a power chain.

Hi-plated chain	Electroless nickel plating (Chemical resistance strengthening treatment, Plating thickness 8 μm)
-----------------	--

Optional control voltage model

The HITACHI electric chain hoist control voltage is 24V, but products with a specified operating voltage can be manufactured when they must match the voltage of other devices.

Control voltage	100V 50/60Hz, 200V 50/60Hz
-----------------	----------------------------

Electric chain hoist with overload prevention unit (with OL)

The HITACHI electric chain hoist that employs an "overload protection unit" was produced in response for demand for increased safety.

*Lowering operation is possible after the overload prevention device operates. First push the lowering button once before beginning the operation.

Features

- Allows cargo handling work while preventing overloading.
- The operation load remains stable even after repeated operation.
- This device was designed to avoid excessive shocks to ensure a long useful life.
- It is an electromechanical type, so it can support optional power source specifications.

Operation principles

Operation of the detection unit built into the reduction gear shuts off the hoist operation circuit. This is HITACHI's unique "overload prevention unit". It detects overload operation and then stops operation while keeping the load hoisted.



With geared limit switch (UDS)

- This type has a built-in switch (UDS switch) that allows the upper and lower limit stop positions to be freely set and that outputs signals of a mid points and other locations by detecting the motor speed.
 - From 2 to 8 contacts is possible.
- 2 of the contacts are used for the upper and lower limit switches. Unless otherwise specified, both the upper and lower limits are set at the time of shipment to be activated approximately 100 mm in front of the limit switch built into the main unit.

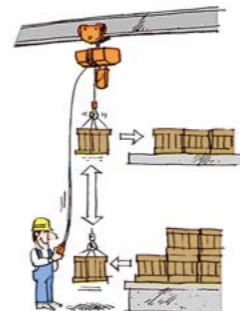

Traverse double speed motorized trolley series

This is suitable for applications requiring a stop system and efficient operation.

Specifications table

Trolley type	1ETN	2ETN	3ETN	5ETN
Rated load	1t	2t	3t	5t
Rating	20%ED, 120Starts/h			
Applicable Beam Width (mm)	75-125	100-150	125-175	

For a speed ratio of 4:1

Trolley type	1ETN	2ETN	3ETN	5ETN
Traveling Speed (m/min)	50Hz	21/5.3		
	60Hz	25/6.3		
Motor Output (kW)	50Hz	0.27/0.07	0.6/0.15	
	60Hz	0.32/0.08	0.7/0.18	
No. of poles	2/8			

For a speed ratio of 2:1

Trolley type	1ETN	2ETN	3ETN	5ETN
Traveling Speed (m/min)	50Hz	21/10.5		
	60Hz	25/12.5		
Motor Output (kW)	50Hz	0.27/0.14	0.6/0.3	
	60Hz	0.32/0.16	0.7/0.35	
No. of poles	2/4			

*When specifying a transverse double speed motorized trolley, the pushbutton switch configuration differs depending on whether the hoist unit and travel crane saddle are single speed or double speed, so contact HITACHI.
*The total value for low speed and high speed is shown for the rating.

Other products with changed specifications

Lift change (extension)

- The lift can be extended within the range in the following table, so specify as needed.
- Options other than those shown in the following table are also possible depending on the conditions, so contact HITACHI.

Chain Length and Chain Container

It is necessary to use a chain container of a capacity fitted to the length of chain to be contained.

	Rated Load(kg)	Chain System	Chain Length(m)	Lift (m) and Name of Container																							
				3	4	5	6	7	8	9	10	11	12	13	14	15	16	17	18	19	20	21	22	23	24		
L Series	150	φ6.3 × 1	LIFT+0.5				Lx								Bx									Cx			
	250	φ6.3 × 1	LIFT+0.5				Lx								Bx									Cx			
	500	φ6.3 × 1	LIFT+0.5				Lx								Bx									Cx			
S Series	1,000	φ7.1 × 1	LIFT+0.7			D					E							F									
	2,000	φ7.1 × 2	2×LIFT+1.4	D		E				F					G												
	3,000	φ7.1 × 3	3×LIFT+2.4	E		F				G																	
F Series	5,000	φ7.1 × 5	5×LIFT+3.9	F		G																					
	1,000	φ7.1 × 1	LIFT+0.7			D					E							F									
	2,000	φ10 × 1	LIFT+0.8	E		F									G									I			
F Series	3,000	φ10 × 2	2×LIFT+1.6	F		G									I												
	5,000	φ10 × 3	3×LIFT+1.8	G							I																

Tropical treatment added

The motor is varnish treated twice when it will be subjected to high humidity conditions.

Insulation grade change

The standard product uses E grade insulation, but F grade insulation is possible (motor only).

On beam first stage

The ET trolley beam width is one grade higher than the standard.

With protective cover

This is a resin coated cloth main unit protective cover.

Upper hook direct connection type

This type directly connects the trolley and hoist body using an I-hook.

Optional chain container

Plastic is the standard specification, but it can also be made of steel plate.

With thermal protector

This product can come with a thermal protector to prevent motor burnout.

Hook dimension / load block weight / chain weight

		L series			S series				F series						
		150kg	250kg	500kg	1t	2t	2.8t	5t	1t	2t	2.8t	5t	(7.5t)	10t	15t
Upper Hook dimension	A	88.5	88.5	88.5	97	127	154	180	97	124	154	180	180	180	—
	B	22.5	22.5	22.5	25	35	45	55	25	28	45	55	55	55	—
	C	27	27	27	29	34	40	48	29	33	40	48	48	48	—
	D	35.5	35.5	35.5	40	45	55	65	40	45	55	65	65	65	—
	E	26	26	26	30	36	46.5	56.5	30	36	46.5	56.5	56.5	56.5	—
Lower Hook dimension	A	85	85	85	105	123	154	186	105	123	154	186	295	295	365
	B	22	22	22	25	35	45	55	25	35	45	55	85	85	102
	C	27	27	27	23	26	42	48	23	26	42	48	68	68	86
	D	35	35	35	40	45	55	65	40	45	55	65	100	100	130
	E	23	23	23	25	36	46.5	56.5	25	36	46.5	56.5	95	95	122
Load block weight (kg)		1.0	1.0	1.0	1.5	6.2	11.0	18.0	1.5	3.7	13	25	65	65	120
Chain weight (kg)	Per 1m chain	0.86	0.86	0.86	1.14	1.14	1.14	1.14	1.14	2.23	2.23	2.23	2.23	2.23	2.23
	Per 1m lift					2.28	3.42	5.7			4.46	6.69	8.92	8.92	13.4

Hook dimension drawing

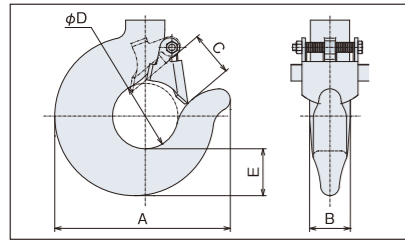

About the method with a stopper

Wheel stopper

After the trolley has been installed on the travel rail, always install a stopper on the end of the travel rail to prevent the trolley from dropping off.

- Avoid using the stopper to stop the trolley by letting it run into the stopper.
- Using a stopper that is a different color from the travel rail is an effective means for preventing the trolley from striking the stopper because it makes the stopper stand out.

Damper

The stopper should be used with rubber or other shock absorbing material to absorb the shock when the trolley strikes the stopper. The rubber damper shown in the figure at right is available, so please make use of it.

Installation of trolley stopper

Runway Beam Width (mm)	Materials (L Shaped Rolled Steel Bar)	H (mm)	Bolts and Nuts
75	50×50×6	30	M10
100		40	
125		50	M16
150	65×65×6	60	M20
175		65	

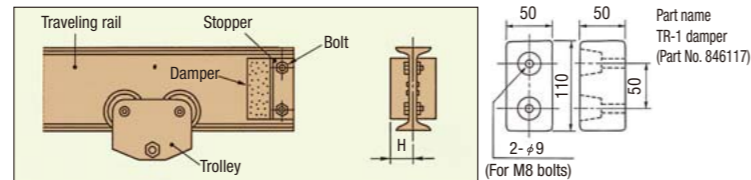

Network

Hitachi Industrial Equipment Systems Co., Ltd. meets customers' needs through the total network which can supply speedy design, production, sales, service and engineering for industrial equipment and systems.

Global Sales Network



Asia & Oceania

China

Hitachi Industrial Equipment Systems (China) Co., Ltd.
(Shanghai Office)
Room2201, Rui Jin Building, No.205
Maoming Road(S) Shanghai 200020
TEL : +86 (21) 5489-2378
FAX : +86 (21) 3356-5070

(Beijing Office)

Room1420, Beijing Fortune Building,
No.5 Dong San Huan Bei Road,
Chao Yang District, Beijing 100004
TEL : +86 (10) 6590-8180
FAX : +86 (10) 6590-8189

(Guangzhou Office)

Room3003, HNA Tower,
8# Linhezhong Road, Tianhe District,
Guangzhou 510610
TEL : +86 (20) 3877-3819
FAX : +86 (20) 2735-3820

Hitachi Industrial Equipment Systems (Hong Kong) Co., Ltd.

8/F, Building 20E, Phase 3, Hong Kong
Science Park, Pak Shek Kok,
New Territories, Hong Kong
TEL : +852 2735-9218
FAX : +852 2735-6793

Taiwan Hitachi Asia Pacific Co., Ltd
3rd Floor, No. 167, Tun Hwa N. Road,
Hung-Kuo Building, Taipei 105, Taiwan
TEL : +886 (2) 2718-3666
FAX : +886 (2) 2514-7664

India

Hitachi India Private Limited
Ground & First Floor, Tower B, World
Mark 1,
Asset Number 11, Aerocity, NH-8, New
Delhi-110037
TEL : +91 (11) 4060-5252
FAX : +91 (11) 4060-5253

Indonesia

PT Hitachi Asia Indonesia
Menara BCA 38th Floor Suite #3804 &
3805 Jl. M. H Thamrin No.1, Jakarta
10310, Indonesia
TEL : +62 (21) 2358-6757
FAX : +62 (21) 2358-6755

Malaysia

Hitachi Industrial Equipment (Malaysia)
Sdn. Bhd.
Lot 6498, Batu 5 3/4 , Lorong Haji Abdul
Manan, 42100 Klang, Selangor,
Malaysia
TEL : +60 3 3290 2323
FAX : +60 3 3290 7570

Philippines

Hitachi Asia Ltd. (Philippines Branch)
Unit 8, 11th Floor Zuellig Bldg., Makati
Avenue corner Paseo de Roxas,
Makati City, Philippines 1225
TEL : +63 (2) 886-9018
FAX : +63 (2) 887-3794

Singapore

Hitachi Asia Ltd.
(Industrial Components & Equipment
Group)
No.30, Pioneer Crescent
#10-15, West Park Bizcentral
Singapore 628560
TEL : +65-6305-7400
FAX : +65-6305-7401

Thailand

Hitachi Asia (Thailand) Co., Ltd.
12th Floor, Ramaland Bldg., No.952
Rama IV Road, Suriyawong Bangrak,
Bangkok 10500, Thailand
TEL : +66 2 632 9292
FAX : +66 2 632 9299

Viet Nam

Hitachi Asia (Viet Nam) Co., Ltd.
(Ho Chi Minh City Office)
R. 8-9-10A, 4th FL., The Landmark
Bldg, 5B Ton Duc Thang, Dist. 1, Ho
Chi Minh City, Vietnam
TEL : +84 28 3829 9725
FAX : +84 28 3829 9729

(Ha Noi Office)

23th Floor, Lotte Center Hanoi, 54 Lieu
Giai St., Cong Vi Ward, Ba Dinh Dist.,
Hanoi, Vietnam
TEL : +84 24 3933 3123
FAX : +84 24 3933 3125

Australia

Hitachi Australia Pty Ltd.
Suite 801, Level 8, 123 Epping Road
North Ryde NSW 2113, Australia
TEL : +61 2 9888 4100
FAX : +61 2 9888 4931

Europe

Germany

Hitachi Europe GmbH
Niederkaßeler Lohweg 191, 40547
Düsseldorf, Germany
Tel: +49 (211) 5283 0
FAX: +49 (211) 5283 649

Latin America

Mexico

Hitachi Industrial Equipment Mexico,
S.A. de C.V.
Av. Rio Seguro 161-E
Parque Tecno Industrial Castro del Rio
C.P. 36810 Irapuato, Guanajuato,
Mexico
Tel : +52-462-693-7088
Fax : +52-462-693-7091

Information in this brochure is subject to change without notice.

Hitachi Industrial Equipment Systems Co., Ltd.

For further information, please contact your nearest sales representative.



Registration number: JACO-EC99J2009
Registration date: July 22, 1996

Hitachi Industrial Equipment Systems Co., Ltd. (Taga Administrative division) obtained ISO 14001 certification, an international standard for environmental management systems.

Registration number: JQA-QMA 12087
Registration date: April 1, 2005

Hitachi Industrial Equipment Systems Co., Ltd. (Taga Administrative division) obtained international standard ISO 9001 certification for the quality assurance of the hoist motor block contained in this brochure.